

## Junction Module (JM™) Enclosure with:



### AS-Interface Input/Relay Output Module (JMR96\_\_\_\_; JMI96\_\_\_\_)

These I/O Modules are designed to function as AS-Interface nodes with termination points for connecting switches/sensors, as well as relay outputs to operate devices such as motors and other high power devices. Relay Outputs can be either Interlocked to operate AC motors or Independent to operate separate AC loads.

#### Inputs and Outputs

- Four (4) Discrete Inputs
- Two (2) Discrete Outputs
- Two (2) Discrete (Relay) Outputs

#### Features

- LED input displays for Inputs 3 & 4
- Fuse protected relay outputs



(See Page 3 detailed wiring instructions)

## JM Enclosure Dimensions (in mm)

Standard Enclosure

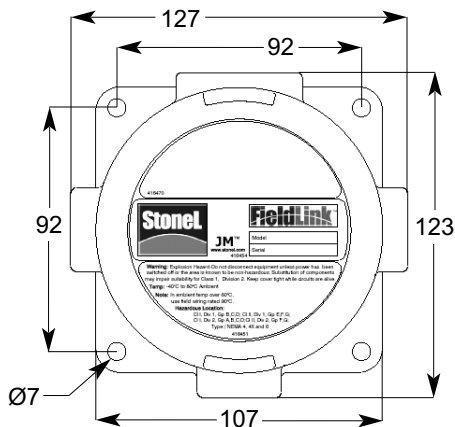

Switched Enclosure

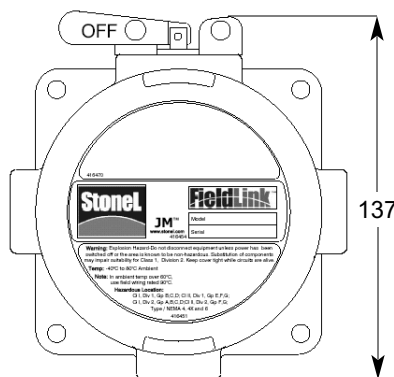

Enclosure w/Cyclone Valve

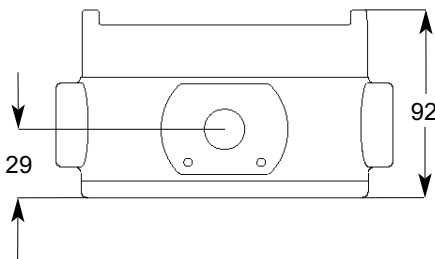
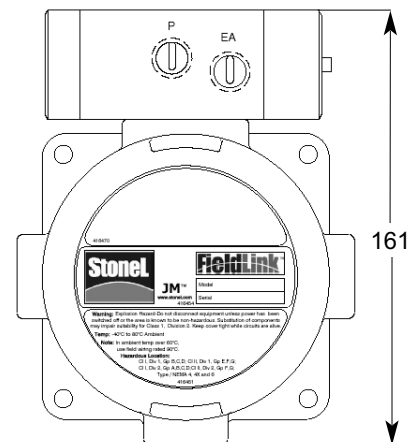

© 2001 StoneL Corporation

**StoneL Corporation**  
 One StoneL Dr  
 26275 US Hwy 59  
 Fergus Falls, MN 56537  
 USA

Telephone: 218.739.5774  
 Toll Free: 800.843.7866  
 Fax: 218.739.5776  
 E-mail: sales@stonel.com  
 Website: www.stonel.com

**Example: JMR9611E3**

	<u>Function</u>	<u>Solenoid</u>	<u>Enclosure</u>	<u>Conduit Entries</u>
<b>JM</b>	<b>R96</b> I/O Relay Module, 4 DI/2 DO/2 Relay DO Independent Outputs, AS-Interface	<b>11</b> No Solenoid (Relay models not available with solenoid)	<b>C</b> Clear Cover	<b>3</b> (3) 1/2" NPT
	<b>I96</b> I/O Relay Module, 2 DI/2 DO/2 Relay DO Interlocked Outputs, AS-Interface		<b>E</b> Epoxy Coated Aluminum	<b>N</b> (4) 1/2" NPT <b>6</b> (3) M20 <b>M</b> (4) M20 <b>9</b> (3) 3/4" NPT <b>T</b> (4) 3/4" NPT

**General Specifications**

<b>Operating Life</b>	Unlimited	<b>Temperature Range</b>	-40° to +80° C (-23° to 180° F)
<b>Materials of Construction</b>		<b>Enclosure Protection</b>	NEMA 4, 4X & 6; IP67
Housing and Cover	Marine grade anodized aluminum epoxy coating	<b>Hazardous Area Ratings</b>	
Clear Cover	Lexan® Polycarbonate	<b>Explosion Proof</b> (Aluminum Cover)	Class I, Div. 1 and 2, Groups B,C,D
Elastomer Seals	Buna-N		Class II, Div. 1 and 2, Groups E,F,G
Fasteners	Stainless Steel	<b>Non-incendive</b> (Clear Cover)	Class I, Div. 2, Groups A,B,C,D
<b>Warranty</b>			Class II, Div. 2, Groups E,F,G
Complete Assemblies	Two Years		(Not all units carry approvals, consult factory)

Lexan is a registered trademark of General Electric Corporation.

**Mounting Instructions**

**Mounting The JM Enclosure**

1. Locate the position where the JM enclosure will be mounted. Ensure that there is sufficient room to operate the disconnect switch levers and to remove the cover.
2. Attach the JM enclosure to a wall or other stationary flat surface using the mounting holes provided.
3. Secure the cover until hand tight

**Attaching Conduit and Fittings**

1. Conduit entries are provided for the convenient attachment of threaded conduit and threaded conduit fittings. Attach threaded fittings and conduits securely.
2. Follow all applicable NEC codes and other regulations.

**Installing & Removing Cover**

1. To insure NEMA 4, 4X, 6 and hazardous location ratings are maintained the cover **must be** completely closed and the O-Ring sealed to keep out water.

## AS-Interface 4 DI/2 DO/2 Relay DO Input/Output Relay Modules

Operating Voltage	AS-Interface voltage	Current Usage	40mA (no I/O enabled)
Inputs	(4) 3mA @ 28 VDC gold contact	AS-Interface Profile	ID Code = F; I/O Code = 7 (4 DI/4 DO)
	mechanical, low power reed, or 2 wire	Default Address	00
	and 3 wire PNP solid state sensors	Bit Assignment	<u>Input Data</u> <u>Output Data</u>
Outputs (Bus Powered)	(2) 28 VDC (4 Watts total power available)	Input 1= DI0	Output 1 = DO2
		Input 2= DI1	Output 2 = DO3
		Input 3= DI2	Output 3 = DO0
		Input 4= DI3	Output 4 = DO1
Relay Outputs	(2) 120/250VAC/30VDC fused @ 2 amps (Interlocked or Independent)	Operating Life	Unlimited
External Voltage (For Relay Outputs)	Up to 250 VAC; 30 VDC	Warranty	Two Years

## Input/Relay Output Module Wiring Diagram and Installation Notes

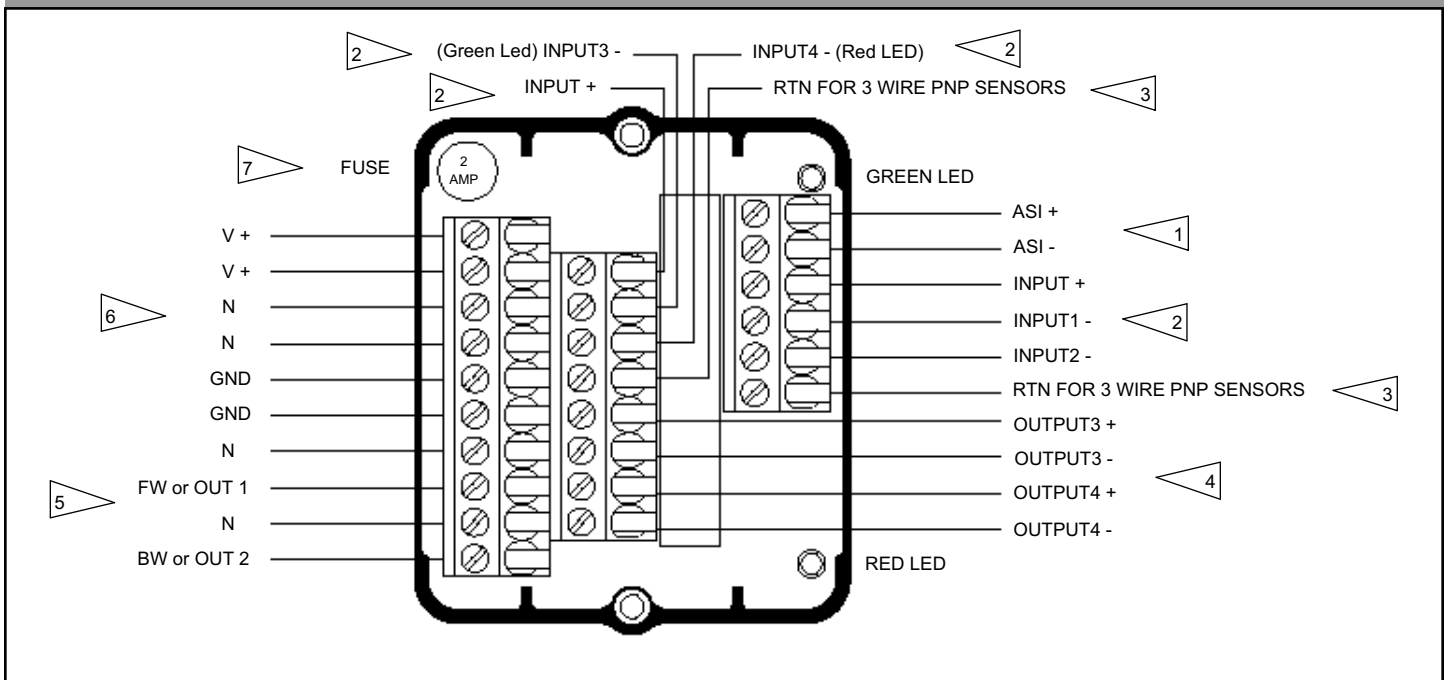

### INSTALLATION NOTES:

1. AS-Interface bus communications connection points.
2. Bus powered Discrete Input connection points for low power (3mA @ 28 VDC) gold contact mechanical switches, low power reed, or 2 wire and 3 wire PNP solid state proximity sensors (max allowable current leakage of sensors 0.3mA) . Red LED is local indication of discrete Input 4 on/off status and the Green LED for discrete Input 3 on/off status.
3. Connection point for the "return" of 3 wire PNP sensors. (See Note 2)
4. 28 VDC Bus powered Discrete Outputs. (4 watts total power available)
5. Connection points for devices to be controlled by the Relay Outputs. OUT1 and OUT2 are markings found on modules with independent outputs (461082). BW And FW markings are used on modules with interlocked outputs (461081). Modules with interlocked outputs are typically used with AC motors. BW and FW represent forward and reverse operation of the motor.
6. Connection points for external 120/250VAC or 30VDC power for devices connected to the Relay Outputs. V+, V+, N, N, GND, GND are redundant termination points. The external power source feeds both Relay Outputs
7. 2 amp replaceable fuse (Part# 434162) for Relay Output protection. (See Note 6)