

Neles™ ball valve

Series M1, M2

Installation, maintenance and
operating instructions

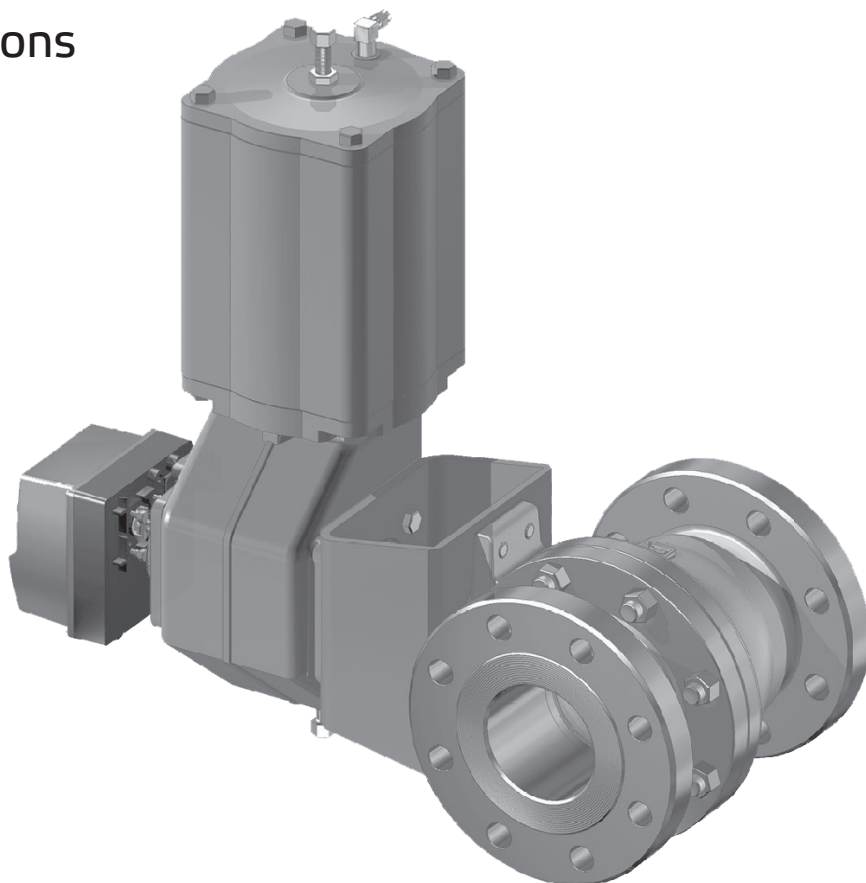

Table of contents

GENERAL	3	INSTALLING AND DETACHING THE ACTUATORS	14
Scope of the manual	3	General	14
Valve construction	3	Installing the M actuator	14
Valve markings	4	Installing the B1C actuator	15
Technical specifications	4	Installing the B1J actuator	15
Valve certifications	5	Detaching B series actuators	15
CE and ATEX marking	5	Installing other manufacturer's actuators	15
Recycling and disposal	5		
Safety precautions	5	TROUBLE SHOOTING TABLE	16
Welding notes	6		
		TOOLS	16
TRANSPORTATION, RECEPTION AND STORAGE	6	ORDERING SPARE PARTS	16
		EXPLODED VIEWS AND PARTS LISTS	17
INSTALLATION	6	Sizes DN 25-40 / 1"-1.5", seat supported ball	17
General	6	Sizes DN 50-200 / 2"-12", seat supported ball	18
Installing in the pipeline	6	Sizes DN 250-400 / 10"-16", trunnion mounted ball	19
Valve insulation	7	Sizes DN 450-600 / 18"-24", trunnion mounted ball	20
Actuator	7		
Commissioning	8	EU DECLARATION OF CONFORMITY FOR ATEX APPROVED VALVES	24
MAINTENANCE	8	TYPE CODE	25
Maintenance general	8		
Changing the gland packing while the valve is still in the pipeline	8	GENERAL SAFETY WARNINGS AND DISCLAIMERS	27
Repairing a jammed or stiff valve without removing it from the pipeline	9	General safety warnings	27
Detaching the actuator from the valve	10	General disclaimers	27
Removing the valve from the pipeline	10		
Dismantling the valve	10		
Checking the parts of a dismantled valve	11		
Replacing parts	11		
Reassembling the valve	11		
TESTING THE VALVE	14		

Subject to change without notice.

All trademarks are property of their respective owners.



This product meets the requirements set by the Customs Union of the Republic of Belarus, the Republic of Kazakhstan and the Russian Federation.

READ THESE INSTRUCTIONS FIRST!

These instructions provide information about safe handling and operation of the valve.

If you require additional assistance, please contact the manufacturer or manufacturer's representative.

SAVE THESE INSTRUCTIONS!

Addresses and phone numbers are printed on the back cover.

1. GENERAL

1.1 Scope of the manual

This manual provides the essential information on the use of M1 and M2 series ball valves. For further information on actuators and other instruments, which are covered only briefly, please refer to separate manuals on their installation, use and maintenance.

NOTE:

As the use of the valve is application specific, a number of factors should be taken into account when selecting the application. Therefore, some of the situations in which the valves are used are outside the scope of this manual.

If you are uncertain about use of the valve or its suitability for your intended purpose, please contact Valmet for more information.

1.2 Valve construction

M1 and M2 series valves are flanged ball valves. The valve is either metal or soft-seated. Valves have two-piece bodies with bolted body joints. In all models, the ball and the stem are separate parts and a stem blow-out is prevented by a shoulder machined on the stem (DN 250/10"-DN 600/24") or by a separate thrust ring /pin and retaining plates (DN 25/1"-DN 300/12").

In seat supported valves a spline driver transmitting the stem torque to the ball connects the stem with the ball. In DN 25/1" and DN 40/1.5" valves the stem is directly connected to the slot in the ball (no separate driver).

Seat supported valves are tight in both flow directions. Tightness is based on pipe pressure, i.e. the pressure differential over the valve forces the ball against the downstream seat. An arrow shows the flow direction in E-seated valves.

The construction of the valves may vary in accordance with customers' wishes. The construction details are indicated in the type code in the identification plate. For more information about the type code, see Section 12.

Seat supported valves are specially designed for demanding shut-off applications involving high operation cycles; with certain restrictions they can also be used in flow control applications.

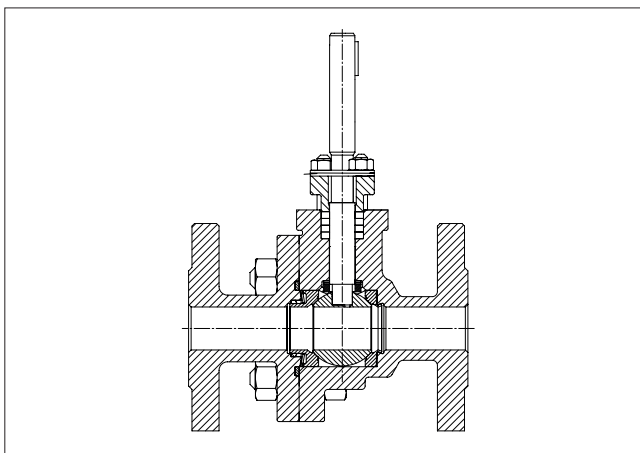

Fig. 1 Construction, sizes DN 25/1" to DN 40/1 1/2", seat supported ball

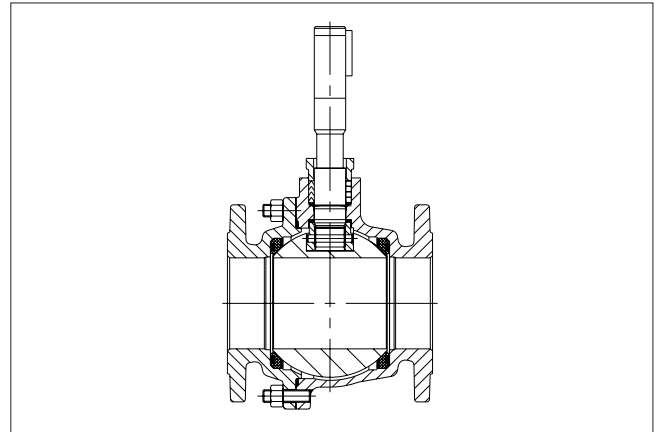

Fig. 2 Construction, sizes DN 50/1" to DN 200/8", seat supported ball

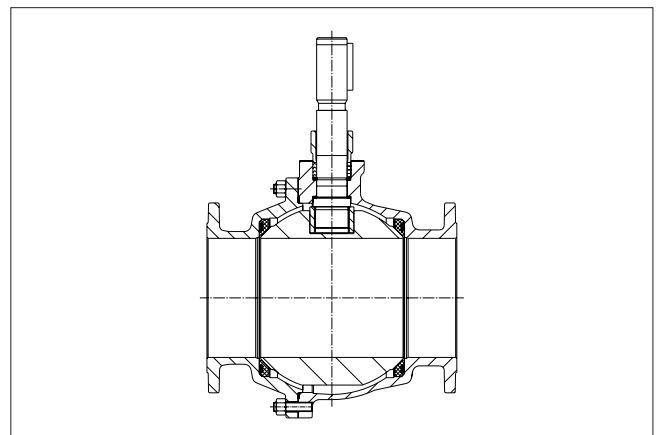

Fig. 3 Construction, sizes DN 250/10" and DN 300/12", seat supported ball

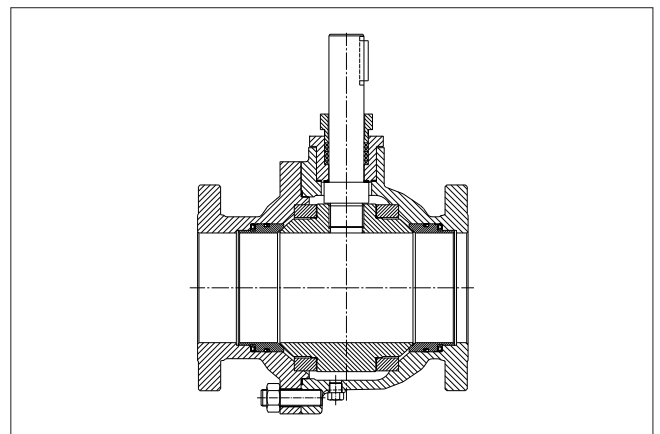

Fig. 4 Construction, sizes DN 250/10" to DN 600/24", trunnion mounted ball

In models with a trunnion mounted ball (Fig. 4) the stem splines transfer the rotating movement directly to the ball. The seats are spring loaded. A 2-seat valve is tight in both flow directions. The tightness-direction of a 1-seat valve is indicated with an arrow.

The sealing effect is the result of the springs forcing the seats against the ball, while the pipe pressure affects the seat upstream.

The valve is intended for on-off and control use. The construction of a supplied valve may differ depending on customer requirement.

The detailed construction is defined by the type coding which is shown on the valve identification plate. Type coding is explained in Section 12.

1.3 Valve markings

Body markings are cast on the body, Fig. 5.

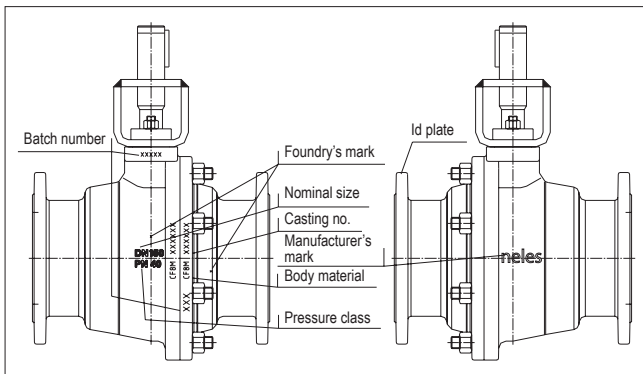

Fig. 5 Valve markings

The valve also has an identification plate attached to it, see Fig. 6.

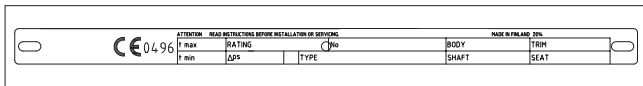

Fig. 6 Identification plate

Identification plate markings:

1. Body material
2. Shaft material
3. Trim material
4. Seat material
5. Maximum/minimum operating temperature
6. Maximum shut-off pressure differential
7. Pressure class
8. Type designation
9. Valve manufacturing parts list no.
10. Model
11. Certification and approvals, eg. CE, ATEX etc

1.4 Technical specifications

Product type

Flanged full bore, ball valve.

Split body design.

Seat supported design:

M1:	DN 25 ... 300
M2:	1" ... 12"

Trunnion design:

M1:	DN 250 ... 600
M2:	10" ... 24"

Pressure ratings

M1:	PN 10, 16, 25, 40.
M2:	ASME 150 & 300

Size range

M1:	DN 25 ... 600
M2:	1" ... 24"

Temperature range:

-50 ... +260 °C Depending on the seat material

-60 ... +480 °F

Design Standards:

M1:

Valve Body: DIN 3840, ISO 7121

Valve Flanges: PN 10 - 40

Face-to-face: ISO 5752 / EN 558-1. Basic series 3, 4 or 12 depending on size and pressure class.

M2:

Valve Body: ASME B16.34

Valve Flanges: ASME B16.5

Face-to-face: 1" ... 6" ASME 150 / 300 and 8" ... 12" ASME 150: ASME B16.10 long, except class 150 NPS01" acc to Table 2, same as in class 300. 8" ... 12" ASME 300: ASME B16.10 short Trunnion 10" ... 24": ASME B16.10 long

Standard materials:

Body: CF8M

Ball: CF8M + hard chrome.

Bearings: PTFE + graphite

Seats: Stainless steel + cobalt based alloy, Xtreme™, Optional PTFE or filled PTFE.

Seals/gaskets: PTFE, graphite, FPM.

Body gasket: Spiral wound with PTFE or graphite filler.

Gland packing: PTFE (V-rings), graphite

Bolting: M1: A2-70

M2: ASTM A 193 gr. B8M

Note! Final valve materials may vary due to application and customer requirements. The final selected materials are shown in the bill of materials of delivered valve.

Certification:

EN 10204 – 3.1 material certificates for body and body cap / bonnet.

Standard options:

Degreasing.

Q-Trim.

Anti-Static (ATEX).

Live loaded construction.

Valve testing:

Each valve is tested for body integrity and seat tightness. The body test pressure is 1.5 x PN.

The standard seat test pressure for metal seated is 1.1 x PN.

The standard seat test pressure for soft seats is 6 bar / 90 psi.

The test medium is inhibited water. Air test upon request.

Valve tightness:

ISO 5208 Rate D for metal seats as standard.

Soft seated valves are bubble tight.

Other tightness rates upon request.

1.5 Valve certifications

A tightness certificate can be granted on request.

1.6 CE and ATEX marking

The valve meets the requirements of the European Directive 2014/68/EU relating to pressure equipment, and has been marked according to the Directive.

When applicable, the valve meets the requirements of the European Directive 2014/34/EU relating to equipment and protective systems intended for use in potentially explosive atmospheres, and has been marked according to the Directive.

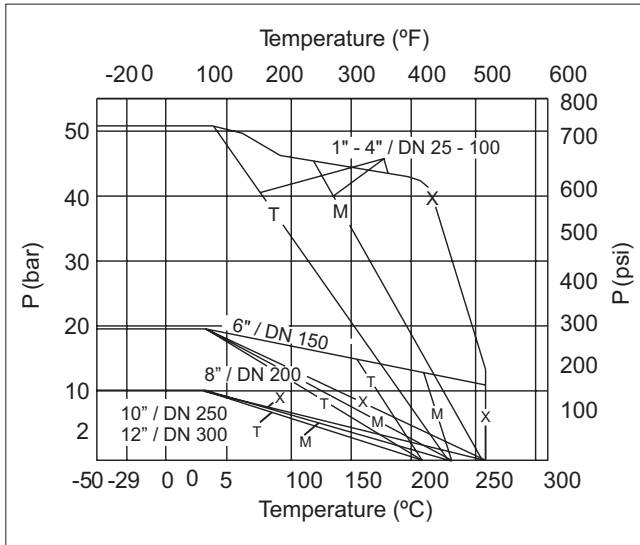

Fig. 7 Pressure differentials permitted in operations (soft-seated valves)

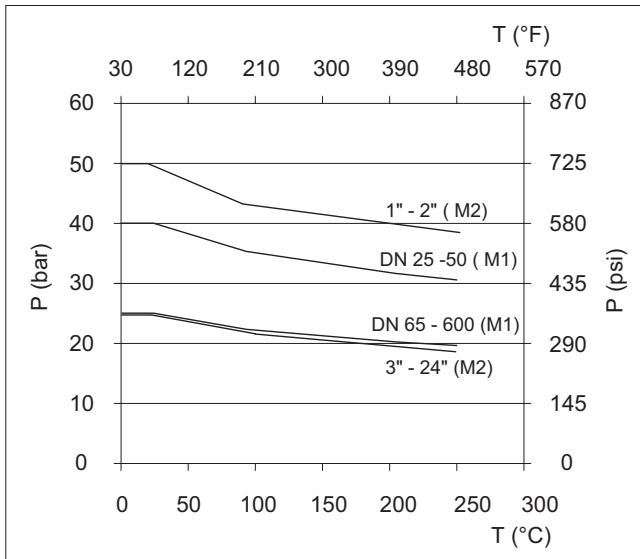

Fig. 8 Pressure differentials permitted in operations (metal-seated valves)

1.7 Recycling and disposal

Most valve parts can be recycled if sorted according to material.

Most parts have material marking. A material list is supplied with the valve. In addition, separate recycling and disposal instructions are available from the manufacturer.

A valve can also be returned to the manufacturer for recycling and disposal against a fee.

1.8 Safety precautions

CAUTION:

Do not exceed the valve performance limitations!

Exceeding the limitations marked on the valve may cause damage and lead to uncontrolled pressure release. Damage or personal injury may result.

CAUTION:

Do not dismantle the valve or remove it from the pipeline while the valve is pressurized!

Dismantling or removing a pressurized valve will result in uncontrolled pressure release. Always isolate the relevant part of the pipeline, release the pressure from the valve and remove the medium before dismantling the valve.

Be aware of the type of medium involved. Protect yourself and the environment from any harmful or poisonous substances. Make sure that no medium can enter the pipeline during valve maintenance.

Failure to do this may result in damage or personal injury.

CAUTION:

Beware of the ball movement!

Keep hands, other parts of the body, tools and other objects out of the open flow port. Leave no foreign objects inside the pipeline. When the valve is actuated, the ball functions as a cutting device. Close and detach the actuator pressure supply pipeline for valve maintenance. Failure to do this may result in damage or personal injury.

CAUTION:

Protect yourself from noise!

The valve may produce noise in the pipeline. The noise level depends on the application. It can be measured or calculated using the Neles Nelprof software. Observe the relevant work environment regulations on noise emission.

CAUTION:

Beware of extreme temperatures!

The valve body may be very cold or very hot during use. Protect people against cold injuries or burns.

CAUTION:

When handling the valve or the valve-actuator assembly, take its weight into account!

Never lift the valve or valve-actuator assembly by the actuator, positioner, limit switch or their piping.

Place the lifting slings securely around the valve body. Damage or personal injury may result from falling parts.

Please consult separate document:

Instructions for lifting Neles products. (See Neles document id: 10LIFT70en.pdf).

ATEX/Ex Safety

CAUTION!

Potential electrostatic hazard, ensure the protection (grounding, etc.) in the process.

CAUTION!

The actual surface temperature of valve is depended on the process temperature. The protection from high or low temperature must be considered by the end user before valve is put into service.

CAUTION!

Ensure the general process and worker protection from static electricity in the facilities.
Note! Within series there is possibility to Category 2, Category 3 and non-ATEX valve.

1.9 Welding notes

WARNING:

Welding and/or grinding stainless steel and other alloys containing chromium metal may cause the release of hexavalent chromium. Hexavalent chromium(VI) or Cr(VI), is known to cause cancer. Be sure to use all appropriate personal protective equipment (PPE) when welding metals containing chromium.

NOTE:

A qualified welder must do the installation welding. The welder and welding procedure should be qualified in accordance with the ASME Boiler and Pressure Vessel Code Section IX or other applicable regulation.

CAUTION:

To prevent damage to the seat and seals, do not allow the temperature of the seat and body seal area to exceed 94 °C (200 °F). It is recommended that thermal chalks be used to check the temperature in these areas during welding.

CAUTION:

Ensure that any weld splatter does not fall onto the valve closing members eg. ball or seats. This may damage critical seating surfaces and cause leaks.

2. TRANSPORTATION, RECEPTION AND STORAGE

Check the valve and the accompanying device for any damage that may have occurred during transport.

Store the valve carefully. We recommend storing indoors in a dry place.

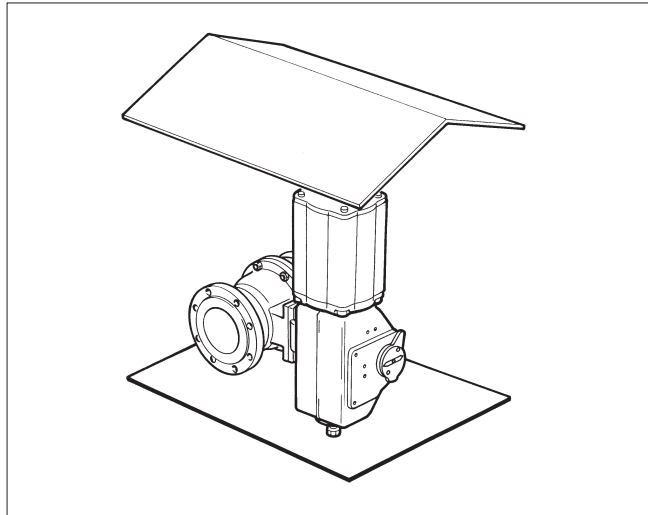

Fig. 9 Storing the valve

Do not remove the flow port protectors until installing the valve. Move the valve to its intended location just before installation. The valve is usually delivered in the open position.

3. INSTALLATION

3.1 General

Remove the flow bore protectors and check that the valve is clean inside. Clean the valve if necessary. Please consult separate document: Instructions for Lifting Neles products. (See Neles document id: 10LIFT70en.pdf)

3.2 Installing in the pipeline

CAUTION:

When handling the valve or the valve-actuator assembly as a whole, bear in mind the weight of the valve or the entire valve-actuator assembly.

Flush the pipeline carefully before installing the valve. Make sure the valve is entirely open when flushing. Foreign particles, such as sand or pieces of welding electrode, will damage the ball and seats.

Remove the flow port protectors and check that the valve is clean inside. Place the valve in the open position.

CAUTION:

On the NPS12" pressure class 300 Short Pattern in seat supported M2 series, the ball protrudes from flange, when ball is in closed position, see figure 10. Failure to install or remove the valve in the open position may result to damage to ball.

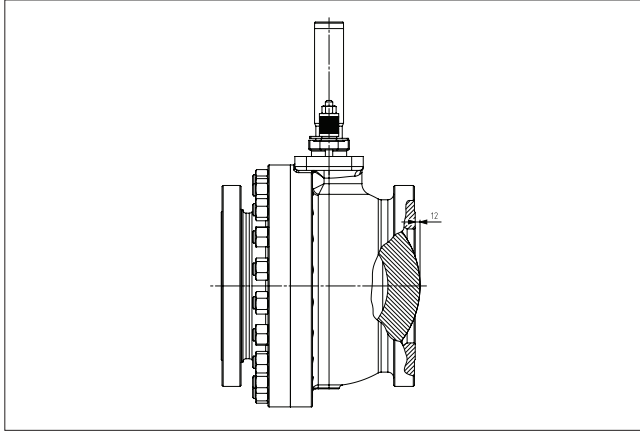

Fig. 10 Seat supported M2 NPS12 Class 300 short pattern valve.

NOTE:

Use screws, nuts, bolts and gaskets equivalent to the fastenings used elsewhere in the pipeline. Center the flange gaskets carefully when fitting the valve between flanges.

NOTE:

Do not attempt to correct pipeline misalignment by means of flange bolting.

The valve may be installed in any position and offers tightness in both directions, except the 1-seat valves with trunnion mounted ball. However we do not recommend installing the valve with the actuator on the underneath side because dirt in the pipeline may then enter the body cavity and damage the gland packing. The position to be avoided is shown in Fig. 11.

It may be necessary to firmly support the pipeline in order to protect the valve from excess stress. Sufficient support will also reduce pipeline vibration and thus ensures proper functioning of the positioner.

To facilitate servicing, it is preferable that the valve be supported by the body, using pipe clamps and supports. Do not fasten supports to the flange bolting or to the actuator, see Fig. 12.

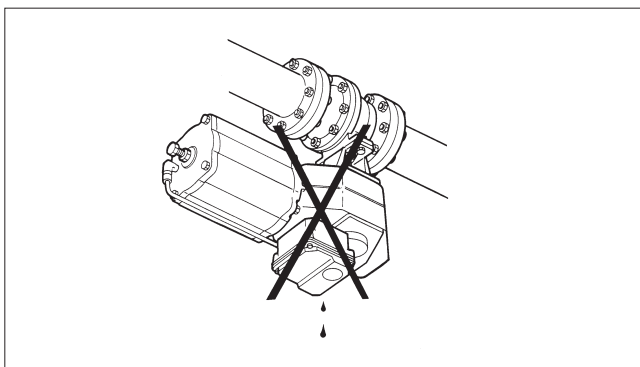

Fig. 11 Avoid this mounting position

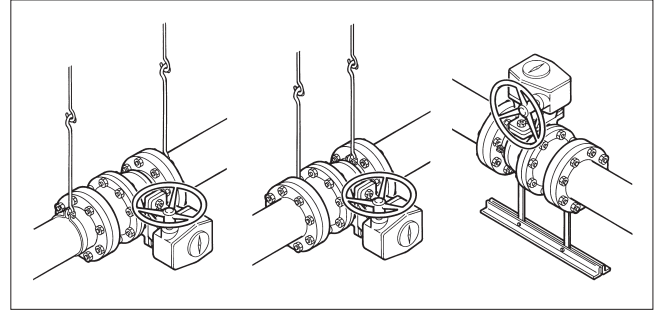

Fig. 12 Supporting the valve

3.3 Valve insulation

If necessary, the valve may be insulated. Insulation must not continue above the upper level of the valve body, see Figure 13.

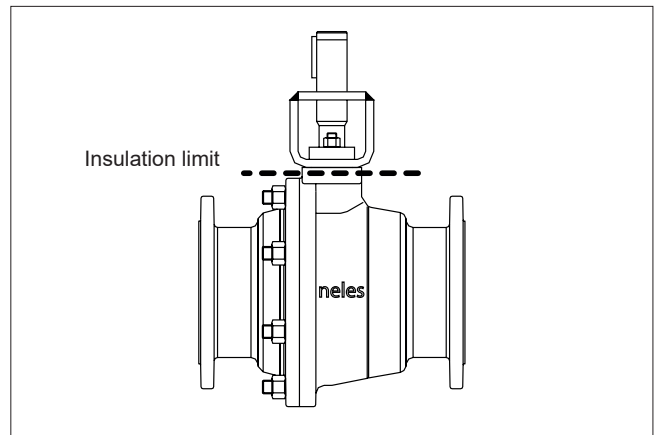

Fig. 13 Insulation of the valve

3.4 Actuator

NOTE:

When installing the actuator on the valve, make sure that the valve-actuator assembly functions properly. Detailed information on actuator installation is given in Section 6 or in the separate actuator instructions.

The valve open/closed position is indicated as follows:

- by an indicator on the actuator or
- by a groove at the end of the ball stem (parallel to the ball flow opening).

If there is any uncertainty about the indicator, check the ball position by the groove.

The actuator should be installed in a manner that allows plenty of room for its removal.

The upright position is recommended for the actuator cylinder.

The actuator must not touch the pipeline, because pipeline vibration may interfere with its operation.

In certain cases it may be considered advantageous to provide additional support to the actuator. These cases will normally be associated with large actuators, extended stems, or where severe vibration is present. Please contact Valmet for advice.

3.5 COMMISSIONING

Ensure that there is no dirt or foreign objects left inside the valve or pipeline. Flush the pipeline carefully. Make sure that the valve is entirely open when flushing.

Ensure that all nuts, pipings, and cables are properly fastened.

Check that the actuator, positioner, and switch are correctly adjusted. Actuator adjustment is explained in Section 6. To adjust the accompanying device refer to the separate control equipment instruction manuals.

4. MAINTENANCE

4.1 Maintenance general

CAUTION:

Observe the safety precautions mentioned in Section 1.8 before maintenance!

CAUTION:

When handling the valve or the valve-actuator assembly as a whole, bear in mind the weight of the valve or the entire assembly.

Although Neles valves are designed to work under severe conditions, proper preventative maintenance can significantly help to prevent unplanned downtime and in real terms reduce the total cost of ownership. Valmet recommends inspecting the valves at least every five (5) years.

The inspection and maintenance interval depends on the actual application and process condition.

The inspection and maintenance intervals can be specified together with your local Valmet experts. During this periodic inspection the parts detailed in the Spare Part Set should be replaced. Time in storage should be included in the inspection interval.

Maintenance can be performed as presented below. For maintenance assistance, please contact your local Valmet office. The part numbers in the text refer to the exploded view and to the parts list in Section 10, unless otherwise stated.

NOTE:

When sending goods to the manufacturer for repair, do not disassemble them. Clean the valve carefully and flush the valve internals. For safety reasons, inform the manufacturer of the type of medium used in the valve (include material safety datasheets (MSDS)).

NOTE:

In order to ensure safe and effective operation, always use original spare parts to make sure that the valve functions as intended.

NOTE:

For safety reasons, replace pressure retaining bolting if the threads are damaged, have been heated, stretched or corroded.

4.2 Changing the gland packing while the valve is still in the pipeline

CAUTION:

Do not remove or dismantle a pressurized valve!

CAUTION:

For safety reasons the retaining plates (42) MUST always be installed as shown in sections 10.1 and 10.2 (DN 25-300/1"-12")!

The V-ring gland packing requires no regular tightening. The gland packing tightness is provided by the pipeline pressure together with gland pressure against the packing rings. In graphite gland packings, tightness is ensured by contact between the gland follower and the packing rings.

The gland packing (69) must be changed if leakage occurs even after the hex nuts (18) have been tightened. The V-ring gland packing must be tightened with care because excess force may damage the V-rings.

- Make sure that there is no pressure in the valve.
- Detach the actuator and the bracket according to the instructions in Section 4.4
- Remove the Key (10)
- Remove the nuts (18) and the retaining plates (42).
- Remove the gland (9).
- Remove the packing rings (69) from around the stem using a knife or other pointed instrument. Make sure that there is no damage to the stem or the counterbore. Please note that the thrust ring (67) may come off as you remove the packing. It should be placed back in its position before installing the new packing (thrust rings are used in 2"-12" seat supported valves). Please note that in seat supported valves sizes 2"-12" the conical face of the thrust ring should point towards the valve.

CAUTION:

Do not remove the locking wire (51) located under the thrust ring (67)!

- Clean the counterbore, if necessary.
- Place the new packing rings (69) over the shaft (5). The gland follower may be used for pushing the rings into the counterbore. Do not damage packing rings in the shaft keyway. See Fig. 14 for proper orientation.

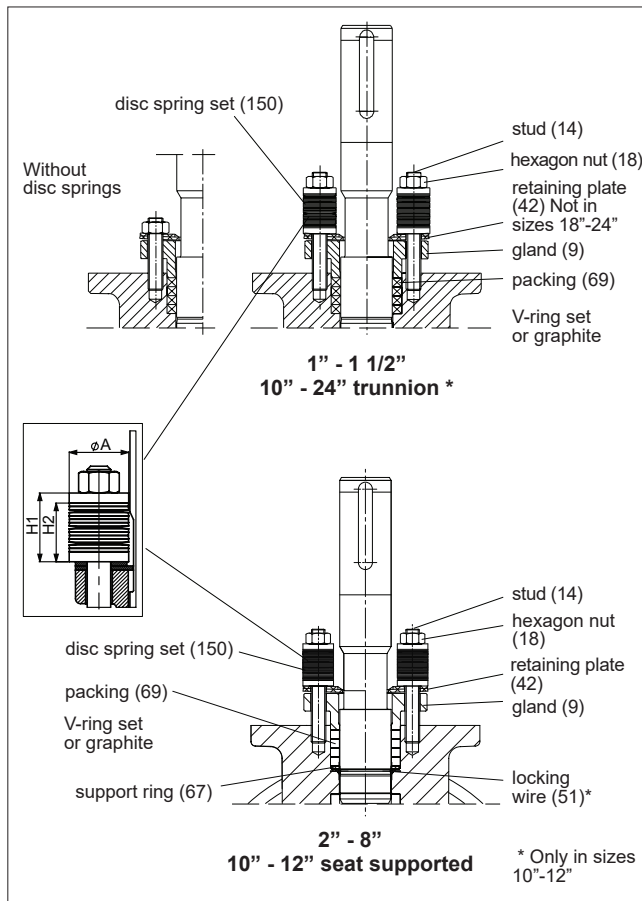

Fig. 14 Packing

- Fasten the gland (9) (and if working on a DN 25-300/1"-12" seat supported valve, the retaining plates (42), place the nuts (18) on the studs (14) and tighten as shown in Tables 1-4. Select correct packing type (PTFE/Graphite) and packing construction (live loaded or not).
- In case of live loaded construction: Pre-compress the packing rings first by tightening the gland nuts without disc spring sets to the torque Tt, see value from tables 1-4. Remove the gland nuts and place the disc spring sets on the gland studs. Tighten the nuts so that the disc spring sets are compressed according to tables 1-4. Lock the nuts with locking compound e.g. Loctite 221

In case of leakage through the packing of a pressurized valve, carefully tighten the nuts until the leakage stops.

SEAT SUPPORTED:

Table 1 Tightening of the gland packing with stainless steel disc spring sets (*). For seat supported construction.

Valve size		Shaft dia (mm)	Spring dimensions		PTFE V-ring		Graphite		ID code of disc spring set
DN	NPS		A (mm)	H1 (mm)	H2 (mm)	Tt (Nm)	H2 (mm)	Tt (Nm)	
50	02"	25	25	33.4	32.4	7	31.4	14	H148584
80	03"	25	25	33.4	32.4	7	31.4	14	H148584
100	04"	35	25	33.4	32.1	10	31.4	19	H148584
150	06"	45	35.5	43.5	42.0	21	40.6	43	H148585
200	08"	55	35.5	43.5	41.8	25	40.5	51	H148585
250	10"	65	50	59	56.9	41	54.9	83	H148587
300	12"	75	50	59	56.7	47	54.3	94	H148587

(*) Disc spring set material change has been done in mid 2019.

Table 2 Tightening of the gland packing with carbon steel+ENP coated disc spring sets. For seat supported construction.

Valve size		Shaft dia (mm)	Spring dimensions		PTFE V-ring		Graphite		ID code of disc spring set
DN	NPS		A (mm)	H1 (mm)	H2 (mm)	Tt (Nm)	H2 (mm)	Tt (Nm)	
50	02"	25	25	30.5	29.4	7	28.4	14	979560
80	03"	25	25	30.5	29.4	7	28.4	14	979560
100	04"	35	25	30.5	29.1	10	28.2	19	979560
150	06"	45	35.5	41	39.1	21	37.6	43	979580
200	08"	55	35.5	41	38.8	25	37.4	51	979580
250	10"	65	50	59	57.1	41	55.2	83	979620
300	12"	75	50	59	56.8	47	54.7	94	979620

TRUNNION MOUNTED:

Table 3 Tightening of the gland packing with stainless steel disc spring sets (*). For trunnion mounted construction.

Valve size		Shaft dia (mm)	Spring dimensions		PTFE V-ring		Graphite		ID code of disc spring set
DN	NPS		A (mm)	H1 (mm)	H2 (mm)	Tt (Nm)	H2 (mm)	Tt (Nm)	
250	10"	55	35.5	43.5	41.8	25	40.5	51	H148585
300	12"	55	35.5	43.5	41.8	25	40.5	51	H148585
350	14"	75	50	59	56.7	47	54.3	94	H148587
400	16"	85	50	59	56.4	53	54.0	106	H148587
450	18"	85	50	59	56.4	53	54.0	106	H148587
500	20"	85	50	59	56.4	53	54.0	106	H148587
500	20"	95	71	73	69.5	125	66.1	250	H148589
600	24"	95	71	73	69.5	125	66.1	250	H148589
600	24"	120	71	73	68.7	154	66.0	309	H148589

(*) Disc spring set material change has been done in mid 2019. Sizes 18" / DN 450 ... 24" / DN600 have been available only with stainless steel disc springs.

Table 4 Tightening of the gland packing with carbon steel+ENP coated disc spring sets. For trunnion mounted construction.

Valve size		Shaft dia (mm)	Spring dimensions		PTFE V-ring		Graphite		ID code of disc spring set
DN	NPS		A (mm)	H1 (mm)	H2 (mm)	Tt (Nm)	H2 (mm)	Tt (Nm)	
250	10"	55	35.5	41	38.8	25	37.4	51	979580
300	12"	55	35.5	41	38.8	25	37.4	51	979580
350	14"	65	50	59	57.3	41	55.3	83	979620
400	16"	75	50	59	57.1	47	54.9	94	979620

4.3 Repairing a jammed or stiff valve without removing it from the pipeline

Jamming or stiff function at the valve may be caused by a flow medium clogging the seat (7) and the ball (3). The ball and the seats can be cleaned without removing the valve from the pipeline by turning the ball to a partly open position and flushing the pipes. If this does not help, follow the instructions below.

4.4 Detaching the actuator from the valve

CAUTION:

When handling the valve package, remember its weight!

NOTE:

To ensure proper reassembly, observe the position of the actuator and positioner/limit switch with respect to the valve before detaching the actuator.

It is generally most convenient to detach the actuator and its auxiliary devices before removing the valve from the pipeline. If the valve package is small or if it is difficult to access, it may be more practical to remove the entire package at the same time.

See Section 6 for details of detaching actuators.

4.5 Removing the valve from the pipeline

CAUTION:

Do not remove or dismantle a pressurized valve!

Make sure that the pipeline is empty and unpressurized and that there is no medium flowing to the pipeline while the valve is being serviced.

Carefully attach the lifting slings, loosen the pipe flange screws and lift the valve using the lifting slings. Make sure that you lift the valve correctly.

4.6 Dismantling the valve

Sizes DN 25-300/1"-12", seat supported

- Place the valve so that the body's hexagon nuts (16) / Body cap (2) point upwards. Use a surface that does not damage the flanges.
- Mark the body halves for correct orientation during reassembly.
- Loosen the gland nuts (18).
- Turn the ball to the closed position.
- Loosen the body's hexagon nuts (16).
- Remove the body cap (2) from the valve. Should the ball seat (7) not stay on the body cap, keep it from falling while you are lifting it out by putting your fingers under the body cap (small sizes) or in the flow bore (large sizes). Watch out for your hand! Lower the body cap onto the surface in a standing position, i.e. onto its flange (see Figure 15).

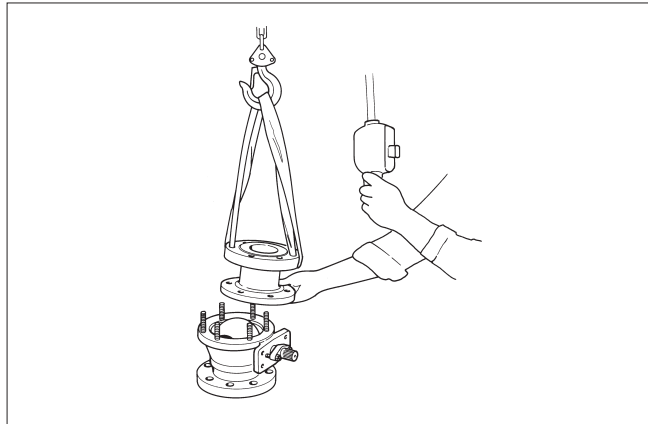

Fig. 15 Lifting a body cap

- Remove the seat (7) from the body cap making sure that it is not damaged during the operation. If the seat is of a locked type, use a special tool which can be ordered from the manufacturer (see Figure 16 and Section 8 'Tools').

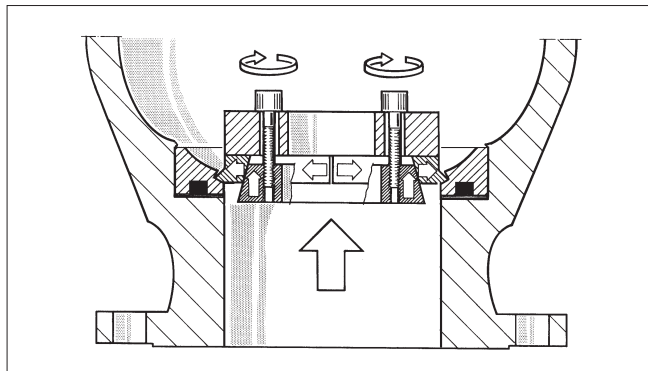

Fig. 16 Removing a locked seat

- Remove the ball (3) from the body (1) by gripping the edges of the flow bore (small sizes) or by passing a lifting sling through the bore (large sizes). To detach the ball from the spline driver (4), turn the ball to the closed position before lifting. Make sure that the ball is not damaged and put it onto a soft surface (see Figure 17).

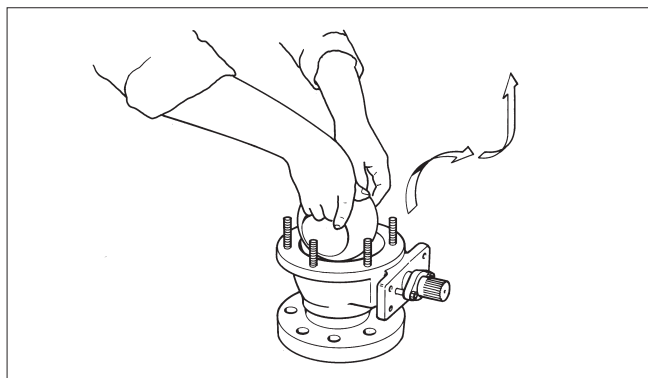

Fig. 17 Removing the ball from the body

- Remove the gland nuts (18), spring sets (150) in live loaded versions, one stud (14), retaining plates (42) and gland (9). Remove the packing (69). Remove the pin (50) (2"-12"). Remove the spline driver (2"-8") or thrust ring (1"-1.5") inside the body. For detailed figures to remove the thrust ring see Fig. 18. Remove the shaft (5) by pulling it outwards. Please note that this will detach the thrust bearings (70) from around the shaft.

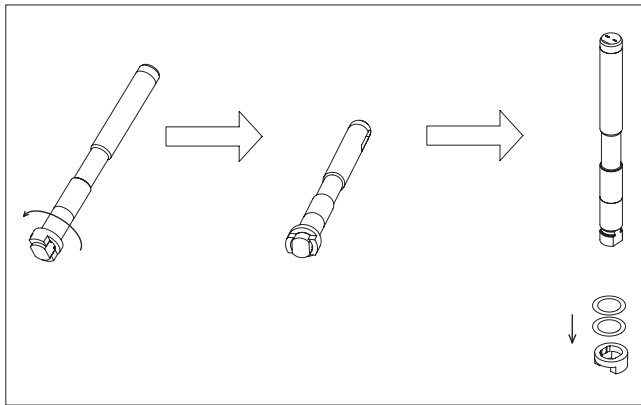

Fig. 18 Detaching the thrust ring in sizes 1" and 1.5"

- For sizes 10"-12", remove the retaining ring (51) before detaching the stem. Use a pointed metal tool and move the stem back and forth sideways. Remove the stem through the body.
- Remove the ball seat (7) from the body (1), if necessary with a special tool. Also remove the back seals (63) from the ball seats and the body gasket (65).

Sizes DN 250-600 / 10"-24", trunnion mounted ball

- Place the valve in a standing position on the pipe flange end. Use a level surface that will not scratch the flanges. See that the body stud nuts (16) are facing upward.
- Mark the the body halves for correct orientation during re-assembly.
- Turn the ball to the closed position.
- Remove the key (10).
- Unscrew the gland nuts (18). Remove the disc spring sets (150), and the gland (9).
- Unscrew the body stud nuts (16).
- Remove the body cap (2). If the seat (7) is not lying on the ball (3), prevent the seat from falling from the body cap and detach it later. Don't leave your fingers between the body cap and the surface!
- Place the removed body cap on its pipe flange.
- Remove the seat (7) from body cap (2) if it is still in place.
- Unscrew the bonnet stud nuts (17). Remove the shaft (5) and bonnet (8). Knock the bonnet off with a piece of wood and a hammer, if needed.
- Lift the ball (3) along with the trunnion plates (89) out of the body (1). Handle the ball carefully and place it on a soft surface.
- Remove the seat (7) from the body (1).
- Remove the trunnion plates (89) from the hubs of the ball.
- Remove the trunnion bearings (99) and the bearing spacers (91) from each trunnion.
- Push the shaft out of the bonnet.
- Remove thrust bearings (70, 71) from the shaft and packing rings (69) from the bonnet (8).
- Remove the body gasket (65) and the bonnet gasket (66).

4.7 Checking the parts of a dismantled valve

- Clean the removed parts.
- Check the stem (5) and the thrust bearings (70).
- Check the ball (3) and the ball seats (7).
- Check the body gasket surfaces.
- Replace any damaged parts.

4.8 Replacing parts

Replace soft parts whenever you dismantle the valve for maintenance. Replace other parts when necessary. By using original spare parts, you can ensure proper functioning of the valve. For ordering the spare parts, see Section 9 ('Ordering spare parts').

4.9 Reassembling the valve

Sizes DN 25-300/1"-12", seat supported

CAUTION:

For safety reasons the retaining plates (42) **MUST** always be installed as shown in 10.1.

- Place the valve body on its pipe flange. Use a surface that does not damage the pipe flange sealing surfaces.
- **P-, V-, C- and S-seats:** Place the back seal (63) in the ball seat (7); see Figures 19 and 20. Place the seat in the body (1).

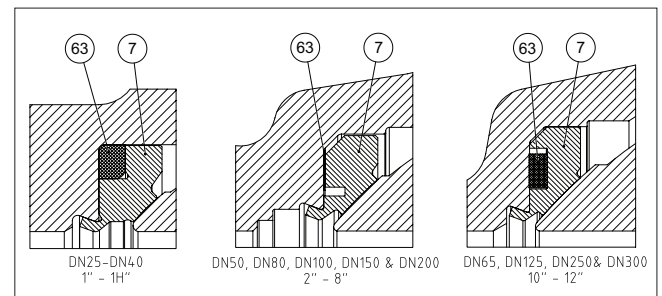

Fig. 19 P-, V- and C-seats

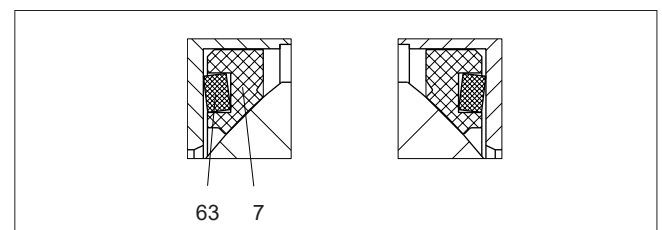

Fig. 20 S-seat

- Lock the P-, V- or C-seat (7) with a special tool supplied with separate instructions (see Section 8 'Tools').

- **X-, T- and M-seats:** Place the seat (7) in the body (1) and body cap (2).

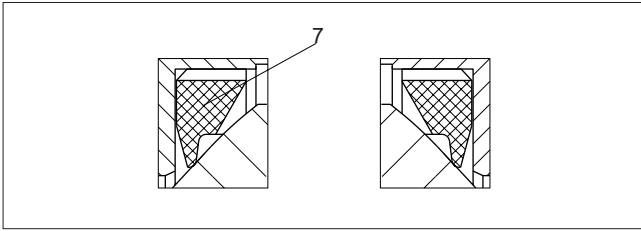

Fig. 21 X-, T- and M-seats

- **E-seat:** Place the back seal (113) in the groove of the seat outer circle (25), Fig. 22. Place the spring (62) in the body. Place the seat in position, please use extra caution not to damage the back seal (113) to the seat pocket edges.

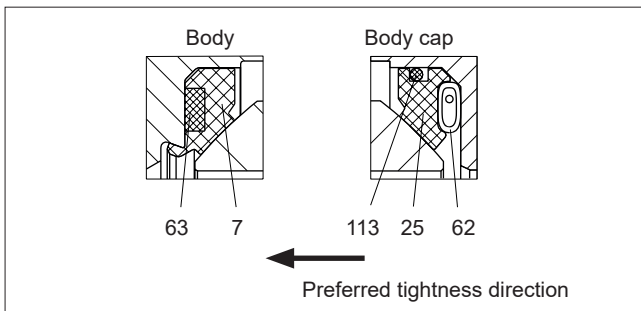

Fig. 22 E-seat

- Place the locking wire (51) in the stem groove (5) in sizes DN 250/10" - DN 300/12". Place the stem partly inside the body from above and place the thrust bearings (70) on the stem from inside the body. Place the thrust bearings against the stem shoulder and place the stem in the valve from inside. Place the spline driver (4, sizes DN 50/2"-DN 200/8") on the shaft spline and lock it with a pin (50). Place the thrust ring (4, sizes DN 25/1"-DN 40/1.5") on the shaft and lock it as illustrated in Fig. 23. Put the ball (3) in its position so that the spline driver / thrust ring (4) is in the ball slot. Screw down the studs (14). Place the support ring (67), (sizes DN 250/10" - DN 300/12"), the packing (69), the gland (9) and the retaining plates (42) in their position. Place the nuts (18) on the studs (14) and screw down them gently.

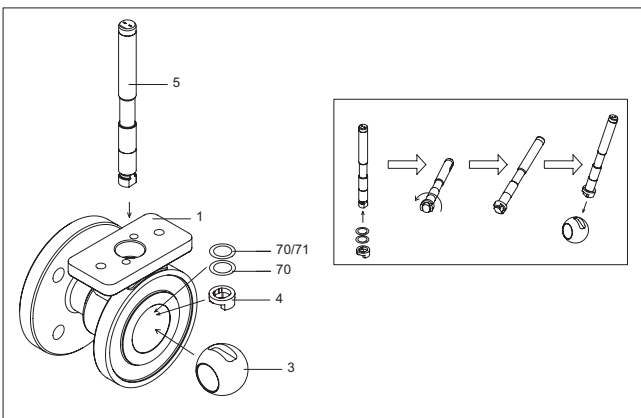

Fig. 23 Assembling the shaft in sizes 1" and 1.5"

- Place the body gasket (65) in the body groove. Screw the studs (12) into the body (1). In sizes DN 25/1" and DN 40/1.5" there are through holes both in body and cap and the joint is made with nuts in both ends of the studs
- Carefully place the body cap (2) on the body. Make sure that the marks made during dismantling are aligned.

- Tighten the body nuts (16). For the best results, press the valve body parts against each other. If this is not possible, make sure that you tighten the nuts evenly. The torque is shown in Table 6, section 4.9.
- To make sure that the ball lies properly between the seats, turn the stem slowly in both directions two or three times.
- Tighten the nuts (18) of the gland by hand as tightly as possible and after that as shown in the instructions in Section 4.2. In case of leakage through the packing of a pressurized valve, carefully tighten the nuts until the leakage stops.
- Observe the same caution in reinstalling the valve that you used in dismantling it. Please also note the instructions in Section 3.

Locking of the seat

A seat locking tool (can be ordered from the manufacturer) and a hydraulic press with suitable capacity are needed for locking.

- Mount the seat with the back seal as described in the earlier section.
- Mount the locking tool carefully over the seat, see Fig. 24.
- Place the valve body/body cap on the bed of the press. The bed surface must be level and non-scratching.
- Align the valve and locking tool properly with the piston of the press.
- Press the tool to lock the seat. See Table 5 for pressing forces.
- Remove the body/body cap from the press and continue the reassembly as described in the earlier section.

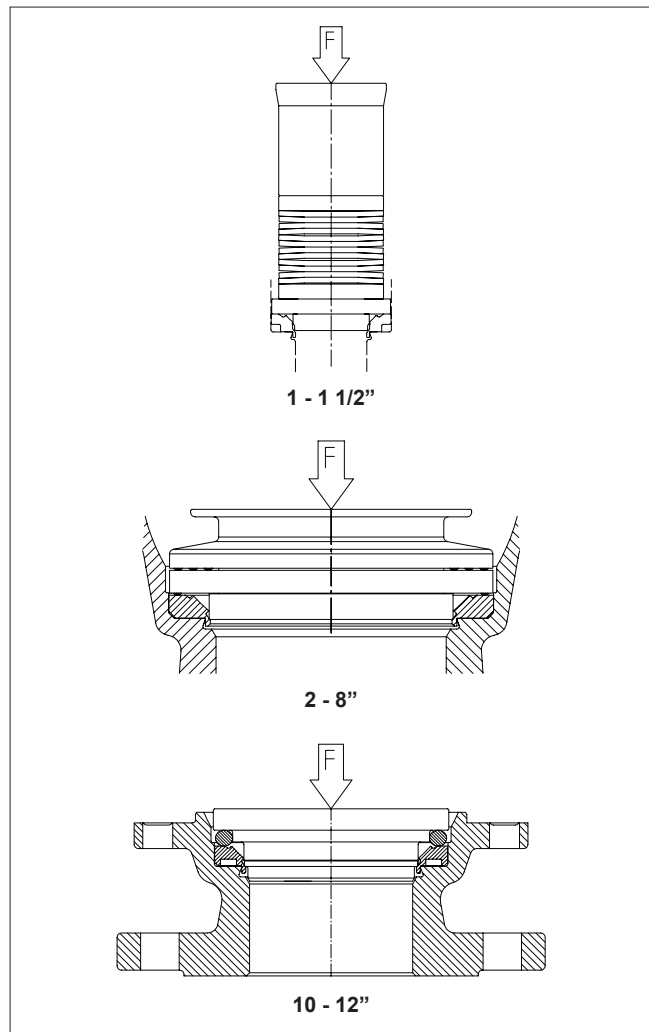

Fig. 24 Locking of the seat

Table 5 Pressing forces for seat locking

Valve size	Force (kN)
01	55
1H	75
02	130
2H	100
03	110
04	125
05	125
06	200
08	400
10	475
12	550

Sizes DN 250-600 / 10"-24", trunnion mounted ball

- Place the valve body (1) and the body cap (2) on the pipe flange end. Use a level surface that will not scratch the flange sealing surfaces.

S-, T-, P- and V-seats: Check the sealing surfaces

- Place the back seal (O-ring) (63) into the groove in the seat. See Figures 25, 26, and 27 .
- For easier assembly, lubricate the O-ring and back-up ring surfaces facing the seats with silicone grease or another suitable substance. Please ensure the compatibility with the flow medium.

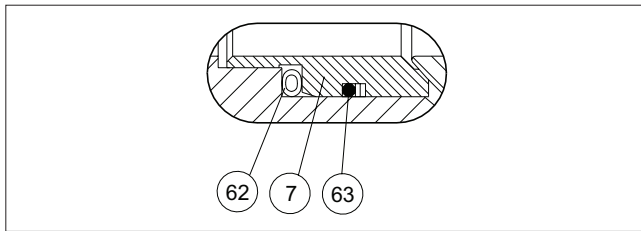

Fig. 25 S-seat

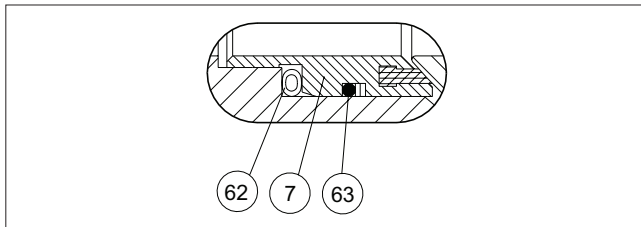

Fig. 26 T-seat

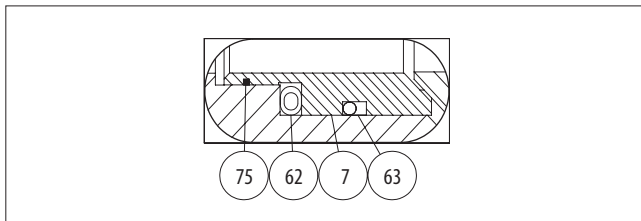

Fig. 27 P- and V-seat

- Place the spring (62) into the groove in the seat (7). Connect the ends of the spring.
- Place the seats into the body and body cap by hand or if necessary, using a plastic mallet. The seat is in correct position when the spring touches the body shoulder.
- Place a trunnion bearing (99) into each trunnion plate (89) counterbore.

- Place a bearing spacer (91) over each ball trunnion, bearing surface facing the ball.
- Fit a trunnion plate over each ball trunnion until the plate rests against the bearing spacer (91). This operation must be performed with care and without excessive force or the bearing will be damaged. It may be necessary to tap the plate on with a plastic mallet.
- Align the trunnion plates (89) relative to the ball port in the closed position.

NOTE:

The shaft will fit into the ball in one position only. There's a larger cog in the splined shaft or added cog in square end shaft and a matching groove in the ball shaft bore. It is essential to note the groove's position during the next assembly step.

- With the ball (3) in the "closed" position, lower the ball/trunnion plate subassembly into the body (1). In sizes DN450-600 / 18"-24", see that the trunnion plate pins (89A) are inserted in the Body (1).

NOTE:

This procedure is critical and careful attention is a must. The outside diameter of the trunnion plates must pilot in the body counterbore. In sizes DN450-600 / 18"-24", the pins (89A) need to align with the holes in trunnion plate (89). Carefully lower the subassembly until a trunnion plate enters the counterbore, and in sizes DN450-600 / 18"-24" pins (89A) go inside the trunnion plate (89). (Usually one trunnion plate will enter the counterbore and the other will be out of position.) Use a plastic mallet or a block of wood to rotate the second trunnion into position. Once trunnion plates are aligned, lower the subassembly until the trunnion plates are seated in the bottom of the counterbore.

- Slide the thrust bearings over the shaft (5).

Sizes DN 250-400 / 10"-16

- Insert shaft subassembly through the bonnet (8) and install packing (69). Refer to Fig. 14 for proper orientation of packing.
- Install the gland (9) over shaft (5) and gland studs. Install the disc springs sets (150) and the gland stud nuts (18) on studs and tighten "finger tight."
- Install the bonnet gasket (66) and the bonnet subassembly over the bonnet studs (10). Note the correct shaft position! Lubricate the threads of studs (13) and tighten the nuts (17) according to values in Table 6.

Sizes DN450 -600 / 18"-24 "

- Insert shaft subassembly through the shaft bore of the body (1). Note the correct shaft position!
- Install the bonnet gasket (66) and then bonnet (8) and over the shaft and the bonnet studs (10). Lubricate the threads of studs (13) and tighten the nuts (17) according to values in Table 6.
- Install the packing (69). Refer to Fig. 14 for proper orientation of packing.
- Install the gland (9) over shaft (5) and gland studs. Install the washers (150a), torsion springs (150b), disc springs sets (150) and the gland stud nuts (18) on studs and tighten "finger tight."

All sizes

- Install the body gasket (65) in the body groove.

- Place the body cap (2) carefully over the body studs (12) and the body (1). See that the flange holes are aligned acc. to the mark made during the dismatling. Take care not to damage the body gasket and the seat (7) in the body cap.
- In sizes DN450-600 / 18"-24" check pins (89A) are inserted in the body cap (2) and that when installing body cap they align with the holes in the trunnion plates (89). The pins can be alternatively inserted first into the trunnion plate holes before lowering the body cap in to body.
- Fasten the body nuts (16). Tighten the nuts gradually, always switching to other side of the valve after every nut. The recommended torques are given in Table 6. The flange faces must in even contact with each other.
- Mount the key (10).
- Cycle the valve slowly a couple of times to insure correct position of the ball between the two seats.
- Pull on the shaft (5) while tightening to assure that shaft and thrust bearings are always in contact with the body. Tighten the gland nuts (18) acc. to Section 4.2 . Check for leakage once the valve is pressurized.
- Install the valve in the pipeline as carefully and accurately as when removing it. Follow the instructions given in Section 3.

Tightening torques of the body joint bolting

Table 6 Tightening torques of the body stud nuts

Material	ISO 3506 A2-70	ASTM A193 gr. B8M cl. 1	ASTM A193 gr. B8M cl. 2
Bolt Size	Tightening Torque (Nm)	Tightening Torque (Nm)	Tightening Torque (Nm)
M8	21	11	31
M10	41	22	60
M12	70	38	100
M14	110	61	170
M16	170	95	260
M18	240	130	350
M20	340	190	420
M22	460	250	560
M24	590	320	720
M27	870	480	870
M30	1200	650	1200
M33	1600	880	1200
M36	2100	1100	1600
M39	2700	1500	2100

NOTE: Threads must be well lubricated

NOTE: ISO 3506 A2-70 utilized in M1 series. ASTM A193 B8M cl.1 utilized in M2 sizes 1"-16", ASTM A193 cl.2 utilized in M2 sizes 18"-24"

5. TESTING THE VALVE

CAUTION:

For pressure testing, use equipment conforming to the correct pressure class!

Test the valve's body pressure after reassembly.

Test the pressure in accordance with an applicable standard. Use the pressure required by the pressure class or the flange bore. Keep the valve in the half open position during the test.

If the tightness of the closure member is also to be tested, please contact the manufacturer.

6. INSTALLING AND DETACHING THE ACTUATORS

6.1 General

CAUTION:

Beware of ball movement!

CAUTION:

Do not detach a spring-return actuator unless a stop-screw is carrying the spring force!

Use suitable mounting parts and couplings when you install the actuators.

Please use tightening torques given in Table 7 when bolting the bracket on to valve.

Table 7 Tightening torques for bracket bolting (for lubricated screws) (Nm)

Screw / Material	M10	M12	M16	M20	M24	M30
A2/A4	41	70	170	340	590	1200
B8M Cl.1	22	38	95	190	320	650
Gr.660	53	91	230	440	770	1500

6.2 Installing the M actuator

- The mark at the end of the stem indicates the direction of the ball flow bore. Turn the valve to the closed position.
- Lubricate the grooves of the actuator and the couplings. Place the coupling on the stem and lock it. Place the bracket on the valve and turn the lubricated screws a few times.
- Turn the actuator to the closed position and push it carefully onto the valve stem on which the coupling has been mounted. Please note the marks on the handwheel and the coupling.
- Lubricate the actuator screws. Tighten all screws.
- Adjust the circular movement of the ball with the hexagon screws located at the side of the housing (see Figure 28). The stop-screw for the open position is nearest to the handwheel on the side of the housing and the screw for the closed position is at the opposite end. The turning directions for the handwheel are marked on the wheel.
- Check the handwheel by turning the valve to the extreme positions. The yellow arrow should indicate the direction of the ball flow bore.

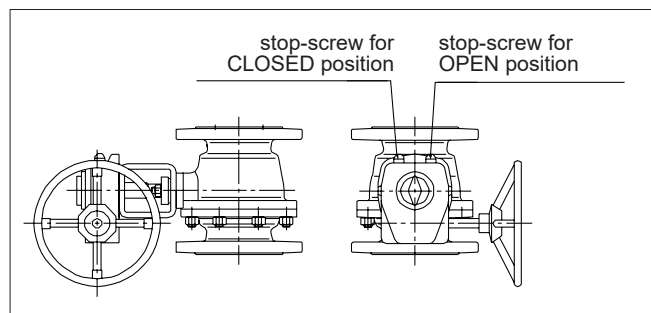

Fig. 28 Open and closed positions of the M actuators

6.3 Installing the B1C actuator

- Turn the valve to the closed position and drive actuator piston to the extreme outward position.
- File off any burrs and clean the stem bore.
- Place the coupling (not always needed) over the stem.
- Note the correct position. The line at the end of the stem (and coupling) indicates the direction of the ball flow bore.
- Lubricate the (coupling and) stem bore. Fasten the bracket loosely to the valve.
- Slip the actuator carefully onto the coupling/stem. We recommend mounting the actuator so that the cylinder is pointing upwards.
- Position the actuator parallel or vertical to the pipeline as accurately as possible. Lubricate the actuator mounting screws and then fasten all screws.
- Adjust the ball open and closed positions by means of the actuator stop screws located at both ends (see Fig. 29). An accurate open position can be seen in the body flow bore. Check that the yellow arrow on the actuator indicates the ball flow opening position. **Watch out for your hand!**

There is no need for stop screw adjustment if the actuator is re-installed in the same valve. Drive actuator piston to the housing end (open position). Turn the actuator by hand until the valve is in the open position. Fasten the actuator in this position as explained above.

- Check the stop screw thread tightness. An O-ring is used for sealing.
- Check that the actuator is functioning correctly. Drive the actuator piston to both cylinder ends and check the ball position and its movement with respect to the actuator (close: clockwise; open: counterclockwise). The valve should be closed when the piston is in the extreme outward position.
- If necessary, change the position of the actuator pointing cover to correctly indicate the valve open/closed position.

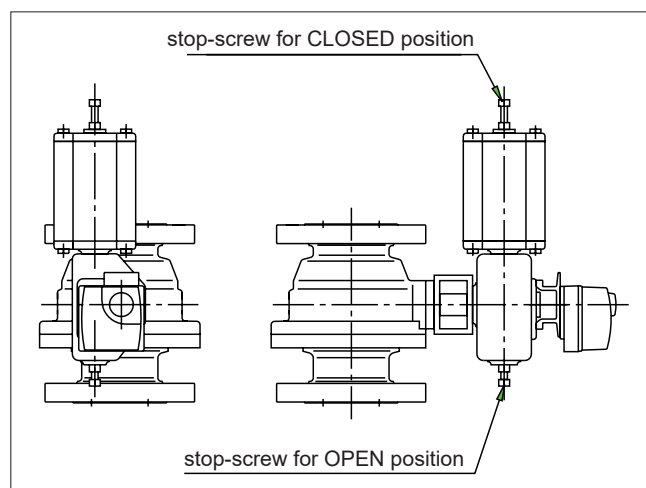

Fig. 29 Open and closed positions of the B series actuators

6.4 Installing the B1J actuator

Spring-return actuators are used in applications where valve opening or closing movement is needed in case the air supply is interrupted. The B1J type is used for spring-to-close operation; the spring pushes the piston towards the cylinder end, the extreme outward position. In turn, the B1JA type is used for spring-to-open operation; the spring pushes the piston towards the housing.

Spring-return actuators are installed in a manner similar to B1C-series actuators, taking into account the following.

B1J type

- Install the actuator so that the piston is in the extreme outward position. The cylinder must not be pressurized and air supply connections must be open. The valve must be in the **closed** position.

B1JA type

- Install the actuator so that the piston is in the cylinder end position at housing side. The cylinder must not be pressurized and air supply connections must be open. The valve must be in the **open** position.
- The rest of the installation procedure is the same as in section 6.3.

6.5 Detaching B series actuators

- Disconnect the actuator from its power source; detach the air supply pipe and control signal cables or pipes from their connectors.
- Unscrew the bracket screws.
- Detach the actuator using a suitable extractor, see Fig. 30. The tool can be ordered from the manufacturer.

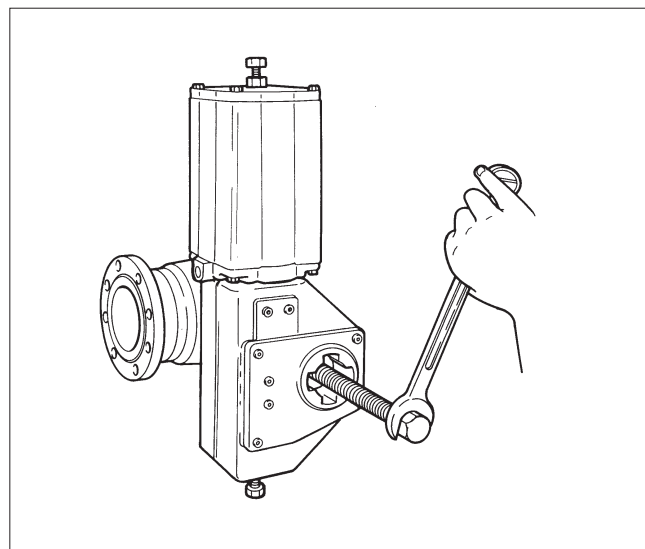

Fig. 30 Extractor

6.6 Installing other manufacturer's actuators

NOTE:

Valmet accepts no responsibility for compatibility of actuators not installed by Valmet.

Other actuators can be installed only if they have an ISO 5211 actuator connection.

7. TROUBLE SHOOTING TABLE

The following Table 8 lists malfunctions that might occur after prolonged use.

Table 8 Trouble shooting

Symptom	Possible fault	Recommended action
Leakage through a closed valve	Wrong stop screw adjustment of the actuator	Adjust the stop screw for closed position
	Faulty zero setting of the positioner	Adjust the positioner
	Damaged seat	Replace seat
	Damaged closing member	Replace the closing member
	Closing member in a wrong position relative to the actuator	Select the correct keyway in the actuator
Leakage through body joint	Damaged gasket	Replace the gasket
	Loose body joint	Tighten the nuts or screws
Irregular valve movements	Actuator or positioner malfunction	Check the operation of the actuator and positioner
	Process medium accumulated on the sealing surface	Clean the sealing surfaces
	Closing member or seat damaged	Replace the closing member or seat
	Crystallizing medium has entered the bearing spaces	Flush the bearing spaces
Gland packing leaking	Gland packing worn or damaged	Replace the gland packing
	Loose packing	Tighten the packing nuts

8. TOOLS

In addition to standard tools, the following special tools might be needed.

- For removal of the actuator:
Extractor tools (Actuator Series B1C/B1J)

Product:	ID:
B1C/B1J 6	303821
B1C 8-11 / B1J 8-10	8546-1
B1C 12-17 / B1J 12-16	8546-2
B1C/B1J 20	8546-3
B1C/B1J 25	8546-4
B1C/B1J 32	8546-5
B1C 40 / B1J 322	8546-6
B1C 50	8546-7
B1C 502	8546-8

- For removal of the locked seats:
Seat removal tool for P-seat.

Product size:	ID:
DN 25 (1")	270073
DN 40 (1½")	270075
DN 50 (2")	270076
DN 65 (2½")	278746
DN 80 (3")	270078
DN 100 (4")	270079
DN 125	270081
DN 150 (6")	270083
DN 200 (8")	270085
DN 250 (10")	270086
DN 300 (12")	270087
DN 350 (14")	280996
DN 400 (16")	280997

- For locking of the seats:
Seat locking tools / Insertion tools (M series P seats & X series GA type K seats)

Product:	ID:
M1MA025P (1")	H018890
M1MA040P (1½")	H018889
M1MA050P (2")	H018886
M1MA065P (2½")	H021153
M1MA080P (3")	H018885
M1MA100P (4")	H018881
M1MA125P (5")	H027818
M1MA150P (6")	H016886
M1MA200P (8")	H018555
M1MA250P (10")	H018556
M1MA300P (12")	H018557

These tools can be ordered from the manufacturer. Always give the valve type designation when ordering.

If you require additional assistance, please contact the manufacturer or manufacturer's representative.

9. ORDERING SPARE PARTS

When ordering spare parts, always include the following information:

- type code, sales order number, serial number (stamped on a valve body)
- number of the parts list, part number, name of the part and quantity required

This information can be found from the identification plate or documents.

10. EXPLODED VIEWS AND PARTS LISTS

10.1 Sizes DN 25-40 / 1"-1.5", seat supported ball

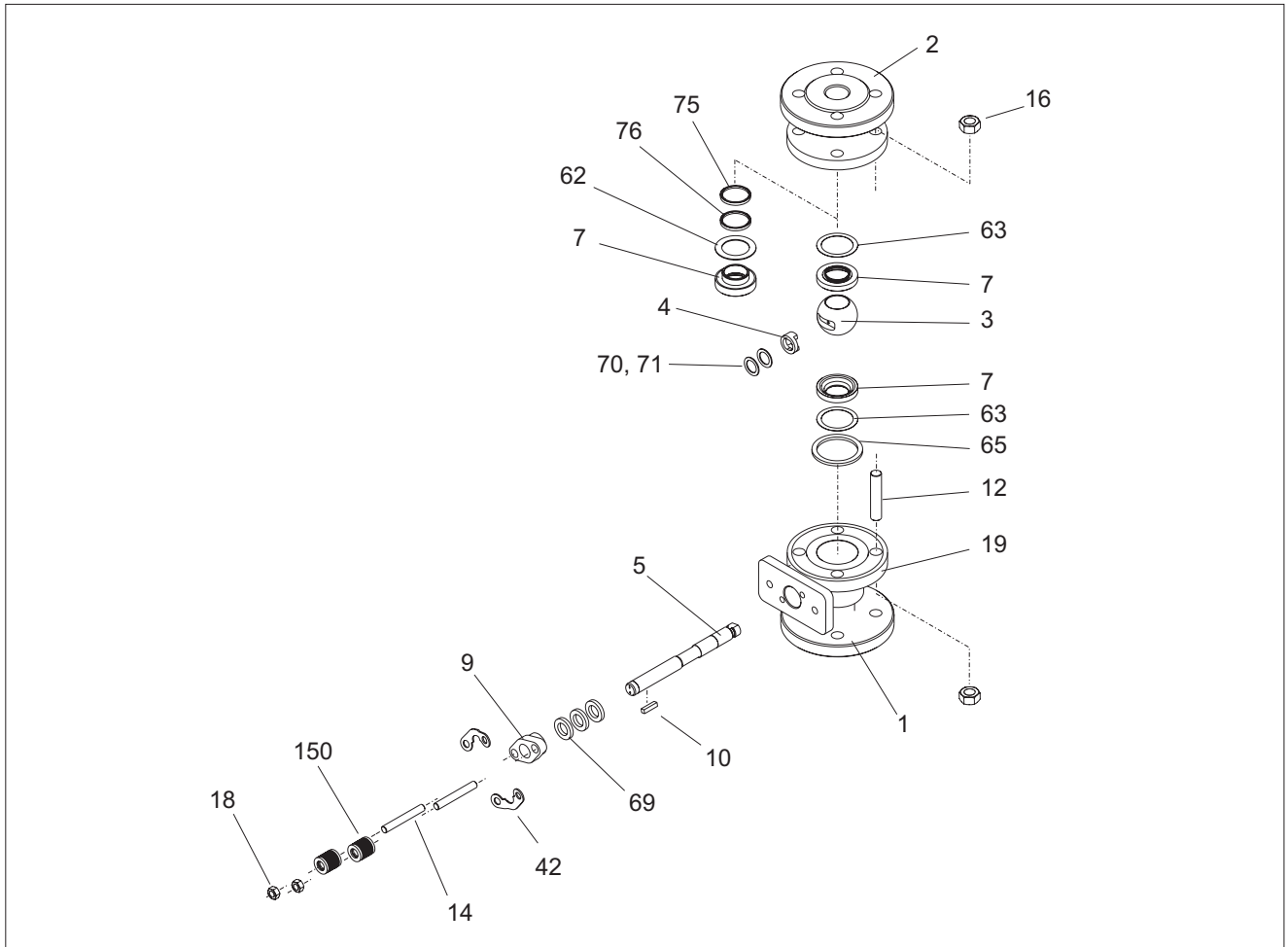

Item	Qty	Description	Spare part category
1	1	Body	
2	1	Body cap	
3	1	Ball/Q-TRIM ball	3
4	1	Thrust ring	3
5	1	Shaft	3
7	1, 2	Ball seat	2
9	1	Gland	
10	1	Key	3
12	4	Stud	
14	2	Stud	
16	8	Hexagon nut	
18	2	Hexagon nut	
19	1	ID plate	
25	1	Ball seat (E)	
42	2	Retaining plate	
50	1	Locking pin	
62	1	Seat spring	1
63	2	Back seal	1
65	1	Body gasket	1
69	1	Packing ring (set)	1
70	1	Thrust bearing	1
71	1	Thrust bearing	
75	1	Seat seal (H)	
76	1	Back-up ring	
150	2	Disc ring set	

Spare part category 1: Recommended soft parts, always needed for the repair. Delivered as a set.

Spare part category 2: Parts for replacing of the seat. Delivered as a set.

Spare part category 3: Parts for replacing of the closing element.

Spares for the full overhaul: All parts from the categories 1, 2 and 3.

10.2 Sizes DN 50-200 / 2"-12", seat supported ball

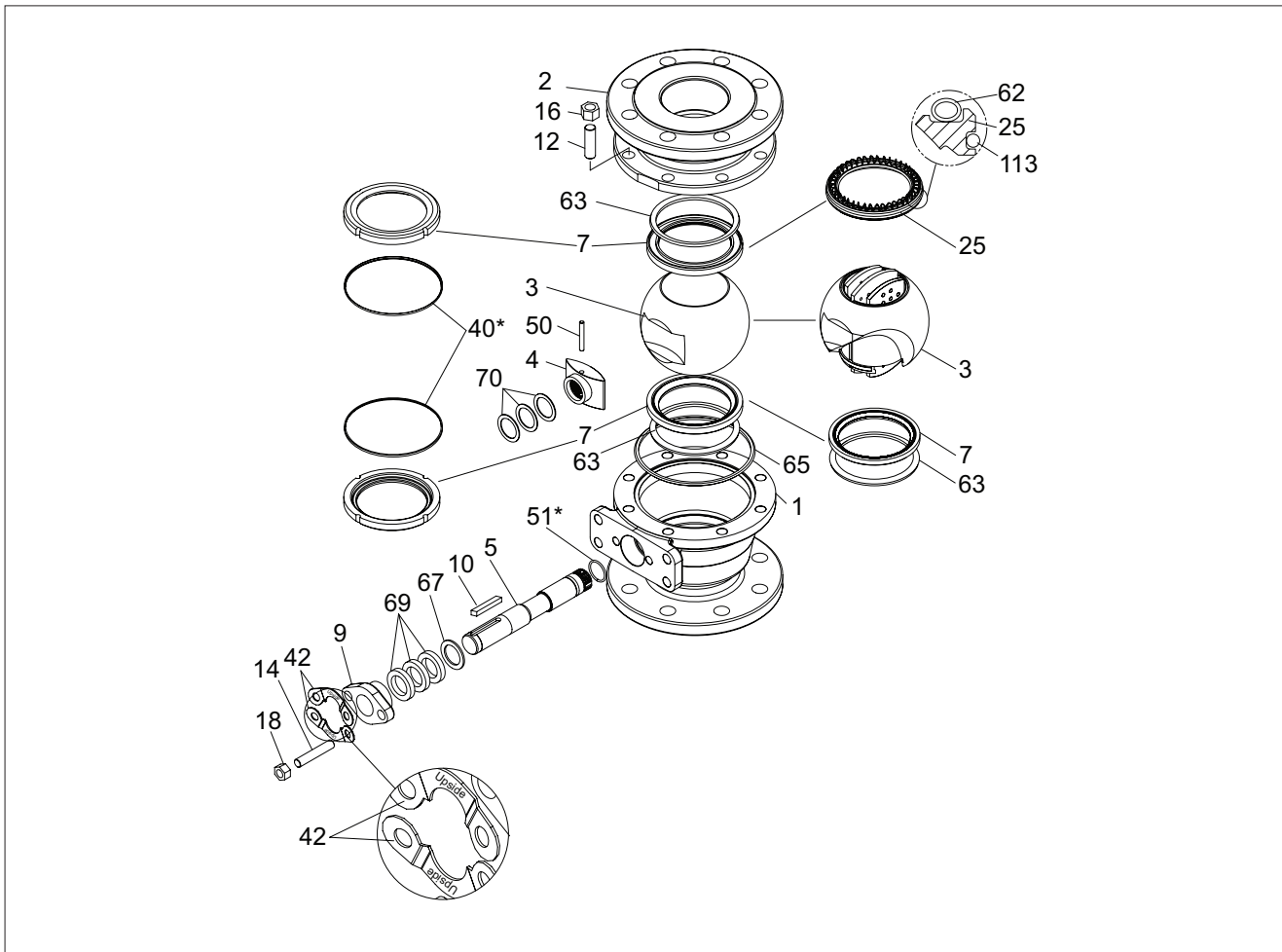

Item	Qty.	Description	Spare part category
1	1	Body	
2	1	Body cap	
3	1	Ball 1 Q-ball	3
4	1	Spline driver	3
5	1	Stem	3
7	2	Seat (P/P1/V/C/S, X/T/M)	2
7	1	Seat (P), when E seat in the body cap	
9	1	Gland	
10	1	Key	3
12		Stud	
14	2	Stud	
16		Hexagon nut	
18		Hexagon nut	
25	1	Seat (E), when (P) seat in the body	
40*	2	Lock ring (X/T/M)	
42	2	Retaining plate	
50	1	Cylindrical pin	
51*	1	Retaining ring	
62	1	Spring (E)	1
63	2	Back seal (P/P1/V/C/S)	1
	1	Back seal (P), when E seat in the body cap	1
65	1	Body gasket	1
67	1	Thrust ring	
69	1	Packing (set)	1
70	3	Thrust bearing	1
113	1	O-ring (E) / lip seal (E)	

*) Only in size 10" - 12"

Spare part category 1: Recommended soft parts, always needed for the repair. Delivered as a set.

Spare part category 2: Parts for replacing of the seat. Delivered as a set.

Spare part category 3: Parts for replacing of the closing element.

Spares for the full overhaul: All parts from the categories 1, 2 and 3.

10.3 Sizes DN 250-400 / 10"-16", trunnion mounted ball

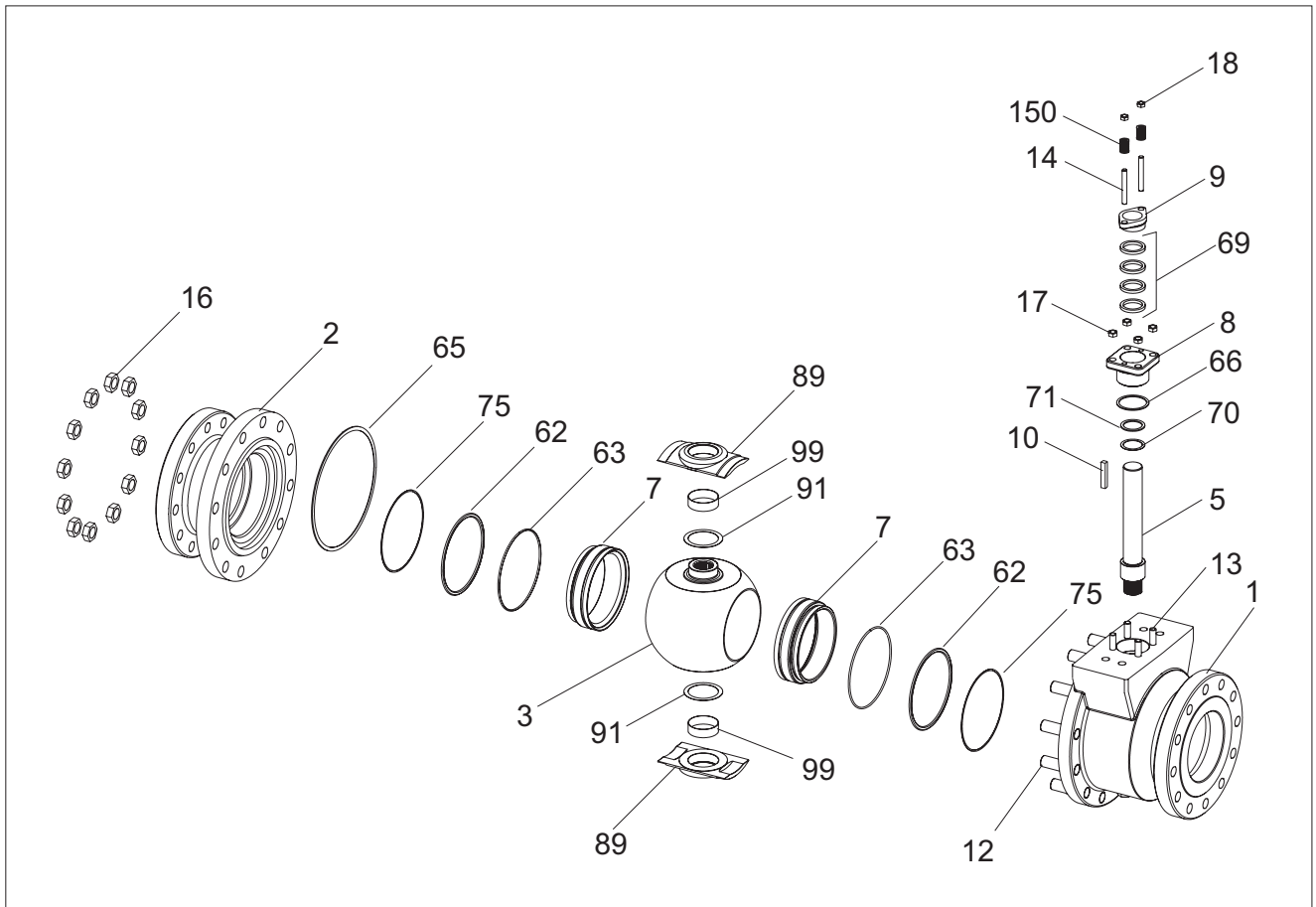

Item	Qty.	Description	Spare part category
1	1	Body	
2	1	Body cap	
3	1	Ball	3
5	1	Shaft	3
7	1 or 2	Seat (S, P, T, V)	2
8	1	Bonnet	
9	1	Gland	
10	1	Key	3
12		Stud	
13		Stud	
14		Stud	
16		Hexagon nut	
17		Hexagon nut	
18		Hexagon nut	
62	1 or 2	Spring	
63	1 or 2	O-ring	1
65	1	Body gasket	1
66	1	Bonnet gasket	1
69	1	Packing / V-ring set	1
70	2	Thrust bearing	3
71	1	Thrust bearing	
75	1 or 2	Braided Seal Square (P, V)	1
89	2	Trunnion plate	
91	2	Bearing spacer	3
99	2	Trunnion bearing	3
150	2	Disc spring set	

Spare part category 1: Recommended soft parts, always needed for the repair. Delivered as a set.

Spare part category 2: Parts for replacing of the seat. Delivered as a set.

Spare part category 3: Parts for replacing of the closing element.

Spares for the full overhaul: All parts from the categories 1, 2 and 3.

10.4 Sizes DN 450-600 / 18"-24", trunnion mounted ball

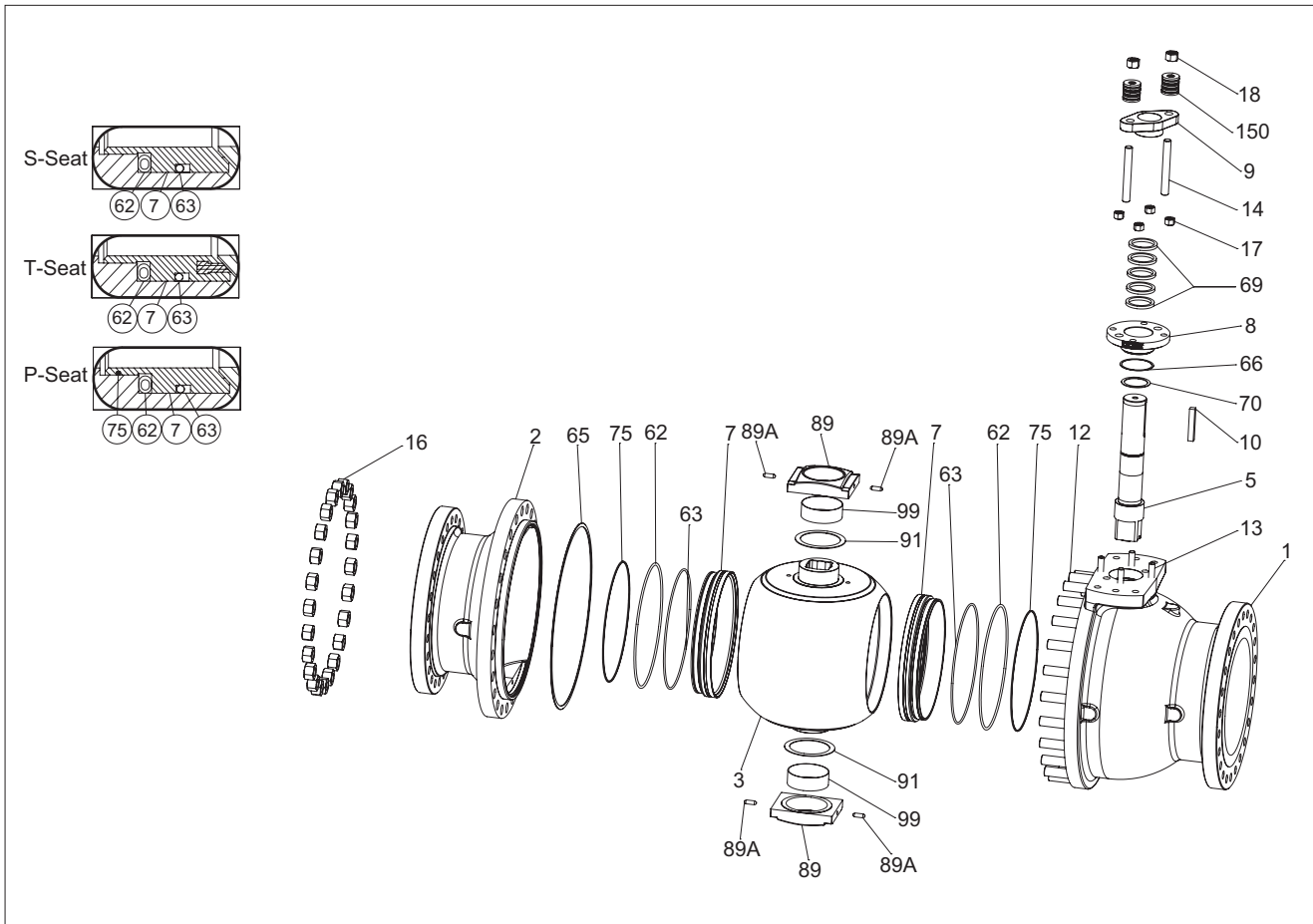

Item	Qty	Description	Spare part category
1	1	BODY	
2	1	BODY CAP	
3	1	BALL	3
5	1	SHAFT	3
7	1 or 2	SEAT (S, P, T, V)	2
8	1	BONNET	
9	1	GLAND	
10	1	KEY	3
12		STUD	
13		STUD	
14		STUD	
16		HEXAGON NUT	
17		HEXAGON NUT	
18		HEXAGON NUT	
19	1	IDENTIFICATION PLATE	
36	1	ANTI-STATIC SPRING	3
62	1 or 2	SPRING	2
63	1 or 2	O-RING	1
65	1	BODY SEAL SPIRAL WOUND	1
66	1	SHEET RING	1
69	1	V-RING SET	1
70	1	THRUST BEARING	1
75	1 or 2	BRAIDED SEAL SQUARE (P, V)	1
89	2	TRUNNION PLATE	
89A	4	PIN	1
91	2	THRUST BEARING	1
99	2	TRUNNION BEARING	1
150	2	DISC SPRING SET	

Spare part category 1: Recommended soft parts, always needed for the repair. Delivered as a set.

Spare part category 2: Parts for replacing of the seat. Delivered as a set.

Spare part category 3: Parts for replacing of the closing element.

Spares for the full overhaul: All parts from the categories 1, 2 and 3.

11. DIMENSIONS AND WEIGHTS

11.1 Seat supported valves

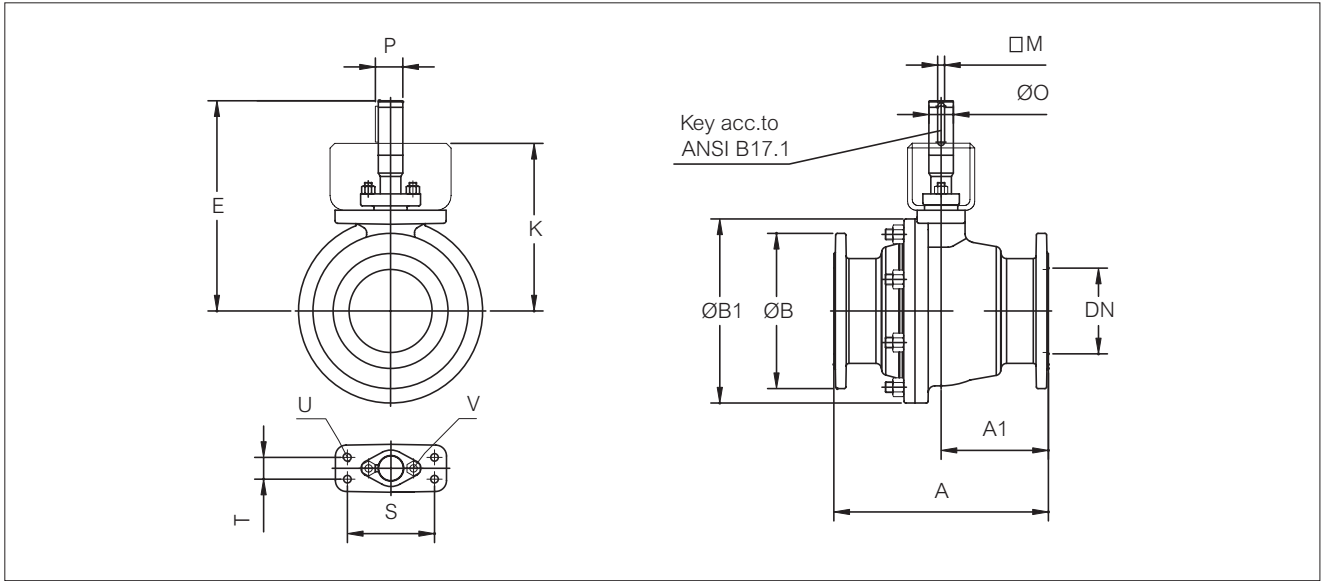

TYPE PN	DN	DIMENSIONS (mm)												WEIGHT (kg)		
		A	A1	ØB	ØB1	E	K	M	ØO	P	S	T	U	V	M1	Q-M1
M1M PN40 (10, 16, 25)	25	165	74	124	110	178	150	4.76	15	17	70	-	M10	M8	5	-
	40	165	70	155	145	206	168	4.76	20	22	70	-	M10	M10	8	-
	50	178	79	165	146	215	168	6.35	25	27.8	110	32	M12	M10	13	14
M1M PN40 (25)	65	270	135	185	154	223	176	6.35	25	27.8	110	32	M12	M10	20	-
	80	282	141	200	195	237	190	6.35	25	27.8	110	32	M12	M10	30	32
	100	305	152.5	235	252	309	250	9.52	35	39.1	130	32	M12	M10	50	55
	125	325	162.5	270	280	331	272	9.52	35	39.1	130	32	M12	M10	80	-
	150	403	201.5	300	346	386	305	12.70	45	50.4	160	40	M16	M14	120	130
M1L PN25	200	502	251	360	432	476	385	12.70	55	60.6	160	55	M20	M14	200	220
	250	568	284	425	512	582	472	15.87	65	71.9	230	90	M24	M20	295	335
	300	648	324	485	584	685	555	19.05	75	83.1	307.4	120	M30	M20	450	505
M1K PN16 (10)	65	270	135	185	154	223	176	6.35	25	27.8	110	32	M12	M10	20	-
	80	203	101.5	200	184	237	190	6.35	25	27.8	110	32	M12	M10	20	22
	100	229	114.5	220	236	309	250	9.52	35	39.1	130	32	M12	M10	35	37
	125	325	162.5	270	280	331	272	9.52	35	39.1	130	32	M12	M10	80	-
M1K PN16	150	394	197	285	338	386	305	12.70	45	50.4	160	40	M16	M14	100	110
	200	457	228.5	340	426	476	385	12.70	55	60.6	160	55	M20	M14	160	180
	250	533	266.5	405	512	582	472	15.87	65	71.9	230	90	M24	M20	280	320
M1J PN10	300	610	305	460	584	685	555	19.05	75	83.1	307.4	120	M30	M20	420	475
	200	457	228.5	340	426	476	385	12.70	55	60.6	160	55	M20	M14	160	180
	250	533	266.5	405	512	582	472	15.87	65	71.9	230	90	M24	M20	280	320
	300	610	305	460	584	685	555	19.05	75	83.1	307.4	120	M30	M20	420	475

TYPE Class	NPS	DIMENSIONS (mm)												WEIGHT (kg)		
		A	A1	ØB	ØB1	E	K	M	O	P	S	T	U	V	M2	Q-M2
M2C Class 150	1	165*	74	124	110	178	150	4.76	Ø 15	17	70	-	M10	M8	5	-
	1 1/2	165	70	155	145	206	168	4.76	Ø 20	22	70	-	M10	M8	8	-
	2	178	79.0	152.4	146	215	168	6.35	Ø 25	27.8	110	32	M12	3/8	11	12
	3	203	101.5	190.5	190	237	190	6.35	Ø 25	27.8	110	32	M12	3/8	25	27
	4	229	110.5	228.6	241	309	250	9.52	Ø 35	39.1	130	32	M12	3/8	40	43
	6	394	197.0	279.5	342	386	305	12.70	Ø 45	50.4	160	40	M16	1/2	100	110
	8	457	228.5	342.9	430	476	385	12.70	Ø 55	60.6	160	55	M20	1/2	175	195
	10	533	266.5	406.4	512	582	472	15.87	Ø 65	71.9	230	90	M24	3/4	290	330
M2D Class 300	12	610	305.0	482.6	592	685	555	19.05	Ø 75	83.1	307	120	M30	3/4	460	515
	1	165	74.0	124.0	110	178	150	4.76	Ø 15	17.0	70	-	M10	M8	5	-
	1 1/2	191	70.0	155.0	145	206	168	4.76	Ø 20	22.0	70	-	M10	M8	10	-
	2	216	89.0	165.1	146	215	168	6.35	Ø 25	27.8	110	32	M12	3/8	15	17
	3	282	141.0	209.6	200	237	190	6.35	Ø 25	27.8	110	32	M12	3/8	35	37
	4	305	152.5	254.0	254	309	250	9.52	Ø 35	39.1	130	32	M12	3/8	60	63
	6	403	201.5	317.5	353	386	305	12.70	Ø 45	50.4	160	40	M16	1/2	135	145
	8	419	209.5	381.0	462	476	385	12.70	Ø 55	60.6	160	55	M20	1/2	240	260
10**	457	208.0	445.5	552	582	472	15.87	Ø 65	71.9	230	90	M24	3/4	365	405	
12**	502	223.0	520.7	626	685	555	19.05	Ø 75	83.1	307	120	M30	3/4	545	600	

* Note: class 150 NPS01" face to face length is according to ASME B16.10 Table 2, same as in class 300 NPS01"

** Note, in sizes Class 300 NPS10" and 12" body side flange is with threaded bolt connection (lug style).

11.2 Trunnion type valves

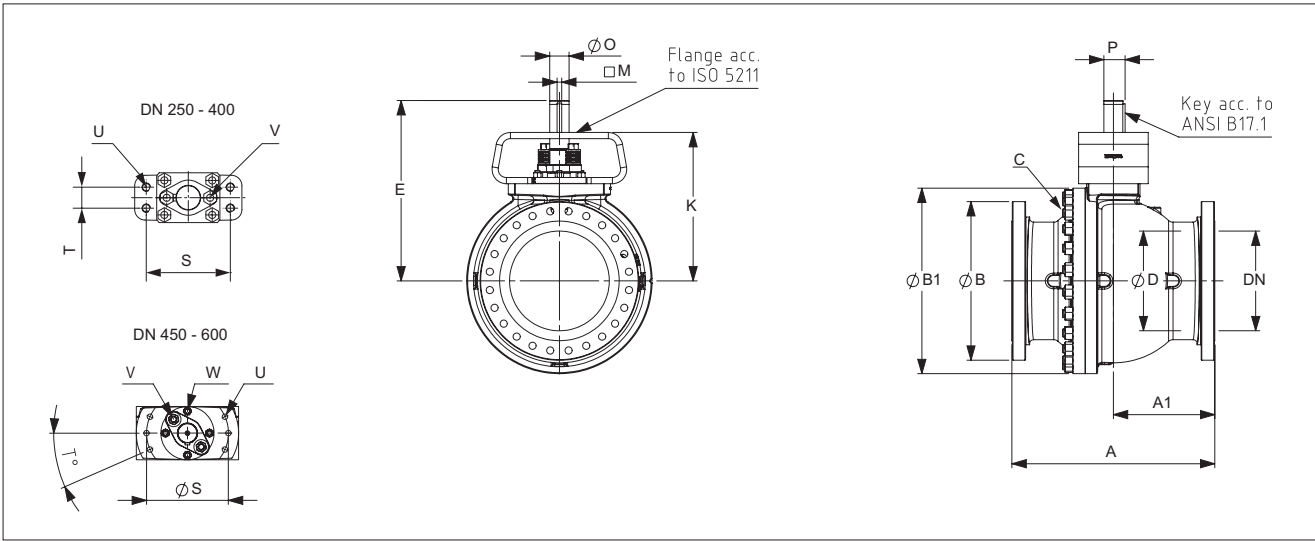

TYPE PN	DN	DIMENSIONS (mm)												WEIGHT (kg)		
		A	A1	ØB	ØB1	E	K	M	ØO	P	S	T	U	V	M1	Q-M1
M1JW/M1JZ PN 10	250	533	267	395	514	562	472	12.70	55	60.60	230	90	M24	M14	325	360
	300	610	305	445	592	605	515	12.70	55	60.60	230	90	M24	M14	480	530
	350	686	343	505	665	741	607	19.05	75	83.15	330	120	M30	M20	635	710
	400	762	381	565	750	779	633	22.23	85	94.63	330	120	M30	M20	840	940
M1KW/M1KZ PN 16	250	533	267	405	514	562	472	12.70	55	60.60	230	90	M24	M14	325	360
	300	610	305	460	592	605	515	12.70	55	60.60	230	90	M24	M14	480	530
	350	686	343	520	665	741	607	19.05	75	83.15	330	120	M30	M20	635	710
	400	762	381	580	750	779	633	22.23	85	94.63	330	120	M30	M20	840	940
M1LW/M1LZ PN 25	250	568	284	425	580	562	472	12.70	55	60.60	230	90	M24	M14	330	370
	300	648	324	485	652	605	515	12.70	55	60.60	230	90	M24	M14	610	660
	350	762	381	555	665	741	607	19.05	75	83.15	330	120	M30	M20	680	750
	400	838	419	620	750	779	633	22.23	85	94.63	330	120	M30	M20	890	980
M1MW/M1MZ PN 40	250	568	284	450	580	562	472	12.70	55	60.60	230	90	M24	M14	330	370
	300	648	324	515	652	605	515	12.70	55	60.60	230	90	M24	M14	610	660
	350	762	381	580	700	741	607	19.05	75	83.15	330	120	M30	M20	800	870
	400	838	419	660	799	779	633	22.23	85	94.63	330	120	M30	M20	1015	1100

TYPE	DN	DIMENSIONS (mm)														WEIGHT		
		ØD	A	A1	ØB	ØB1	E	K	M	ØO	P	ØS	T	U	V	W	C	kg
M1JW/M1JZ PN 10	450	436	864	432	615	800	794	648.5	22.23	85	94.63	330	21.3	M30	M20	M20	M27	981
	500	487	914	457	670	885	811.5	665.5	22.23	85	94.63	330	21.3	M30	M20	M20	M27	1288
	600	589	1067	533.5	780	1041	987	831	22.23	95	104.83	400	23.6	M30	M30	M24	M30	2037
M1KW/M1KZ PN 16	450	436	864	432	640	800	794	648.5	22.23	85	94.63	330	21.3	M30	M20	M20	M27	1011
	500	487	914	457	715	885	811.5	665.5	22.23	85	94.63	330	21.3	M30	M20	M20	M27	1328
	600	589	1067	533.5	840	1041	987	831	22.23	95	104.83	400	23.6	M30	M30	M24	M30	2141
M1LW/M1LZ PN 25	450	436	914	457	670	785	794	648.5	22.23	85	94.63	330	21.3	M30	M20	M20	M24	1098
	500	487	991	495.5	730	880	811.5	665.5	22.23	85	94.63	330	21.3	M30	M20	M20	M27	1438
	600	589	1143	571.5	845	1050	987	831	22.23	95	104.83	400	23.6	M30	M30	M24	M30	2219
M1MW/M1MZ PN 40	450	436	914	457	685	825	794	648.5	22.23	85	94.63	330	21.3	M30	M20	M20	M36	1210
	500	487	991	495.5	755	906	882	726	22.23	95	104.83	400	23.6	M30	M30	M24	M39	1652
	600	589	1143	571.5	890	1060	1090	885	31.75	120	133.75	460	23.6	M30	M30	M24	M39	2709

TYPE PN	NPS	DIMENSIONS (mm)												WEIGHT (kg)		
		A	A1	ØB	ØB1	E	K	M	ØO	P	S	T	U	V	M2	Q-M2
M2CW/M2CZ Class 150	10	533	267	405	514	562	472	12.70	55	60.60	230	90	M24	M14	325	360
	12	610	305	485	592	605	515	12.70	55	60.60	230	90	M24	M14	480	530
	14	686	343	535	665	741	607	19.05	75	83.15	330	120	M30	M20	635	710
	16	762	381	595	750	779	633	22.23	85	94.63	330	120	M30	M20	840	940
M2DW/M2DZ Class 300	10	568	284	445	580	562	472	12.70	55	60.60	230	90	M24	M14	330	370
	12	648	324	520	652	605	515	12.70	55	60.60	230	90	M24	M14	610	660
	14	762	381	585	700	741	607	19.05	75	83.15	330	120	M30	M20	800	870
	16	838	419	650	799	779	633	22.23	85	94.63	330	120	M30	M20	1015	1100

Type	DN	DIMENSIONS, mm															WEIGHT	
		ØD	A	A1	ØB	ØB1	E	K	M	ØO	P	S	T	U	V	W	C	kg
ASME 150	450	436	914	457	710	825	793,9	645,7	22,23	85	95,68	330	1235	M30	M20	M20	M27	1001
	500	487	991	495,5	775	906	881	725	22,23	85	105,87	330	1692	M30	M20	M20	M27	1304
	600	589	1143	571,5	915	1060	1090	885	31,75	95	136,54	400	2636	M30	M30	M24	M30	2087
ASME 300	450	436	864	389,5	635	800	793,9	645,7	22,23	85	95,68	330	21,3	M30	M20	M20	M36	1235
	500	487	914	457	700	885	811	665	22,23	95	95,68	400	23,6	M30	M30	M24	M39	1692
	600	589	1067	533,5	815	1041	987	831	22,23	120	105,87	460	23,6	M30	M30	M24	M39	2636

Type	NPS	DIMENSIONS, inch															WEIGHT	
		ØD	A	A1	ØB	ØB1	E	K	M	ØO	P	S	T	U	V	W	C	lbs
ASME 150	18	17.17	35.98	17.99	27.95	32.48	31.26	25.42	0.88	3.35	3.77	12.99	48.62	M30	M20	M20	M27	2224
	20	19.17	39.02	19.51	30.51	35.67	34.69	28.54	0.88	3.35	4.17	12.99	66.61	M30	M20	M20	M27	2898
	24	23.19	45.00	22.50	36.02	41.73	42.91	34.84	1.25	3.74	5.38	15.75	103.78	M30	M30	M24	M30	4638
ASME 300	18	17.17	34.02	15.33	25.00	31.50	31.26	25.42	0.88	3.35	3.77	12.99	0.84	M30	M20	M20	M36	2744
	20	19.17	35.98	17.99	27.56	34.84	31.93	26.18	0.88	3.74	3.77	15.75	0.93	M30	M30	M24	M39	3760
	24	23.19	42.01	21.00	32.09	40.98	38.86	32.72	0.88	4.72	4.17	18.11	0.93	M30	M30	M24	M39	5858

12. EU DECLARATION OF CONFORMITY FOR ATEX APPROVED VALVES



EU DECLARATION OF CONFORMITY

for ATEX approved valves



Manufacturer:
Valmet Flow Control Oy,
01380 Vantaa, Finland
*Valmet Flow Control (Jiaxing) Co., Ltd.
Jiaxing, China
*) Also manufactures certain series

EU Authorised Representative: Valmet Flow Control Oy, Vanha Porvoontie 229, 01380 Vantaa, Finland. Contact details: [+358 10 417 5000](tel:+358104175000)

This declaration of conformity is issued under the sole responsibility of the manufacturer.

Product:	Neles Ball valves
Type:	D-series (D1, D2, D3, D4, D5), E-series (E2, E6), *M-series (M1, M2, M9, MH), S6-series, T-series (T2, T3, T4, T5), *X-series (XA, XB, XC, XG, XH, XJ, XM, XT, XU)
ATEX group and category:	II 2 GD, II 3 GD
Ex GAS:	Ex h IIC 85°C...Tmax Gb/Gc
Ex DUST:	Ex h IIIC T85°C...T(Tmax) Db/Dc

Tmax= valve max. temperature in name plate

Manufacturer's certificates:

Standard / Directive	Notified Body and NoBo number	Certificate No.
ISO 9001:2015	LRQA (Certification body)	10531829
PED 2014/68/EU Module H	DNV Business Assurance Italy S.r.l. 0496	142306-2013-CE-FIN-ACCREDIA
ATEX 2014/34/EU Annex IV	DNV Product Assurance AS Norway 2460	Presafe 18 ATEX 91983Q Issue 6

ATEX 2014/34/EU Annex VIII technical files are archived by Notified Body number 0537

The object of the declaration described above is in conformity with the relevant Union harmonisation legislation:

PED 2014/68/EU	Valve
ATEX 2014/34/EU	Non-electrical equipment

Main components:

Valve: The valve is suitable for service up to PED Cat III Valve design standard: ASME B16.34

Installation, Maintenance and Operating instructions manual (IMO) must be followed before installation in order to ensure proper and safe mounting and usage of equipment.

The product above is manufactured in compliance with the applicable European directives and technical specifications/standards EN10204:3.1. The product is in conformity with the customer order.

Instrumentation and accessories having equal protection concept, level and performance specification with the original can be presumed to be in conformity with this Declaration of Conformity.

Protection from e.g. static electricity caused by the process or connected equipment must be considered by the user (EN 60079-14 § 6). EN 60079-19 applies for modifications.

Non-electrical equipment is according EN 80079-37:2016 and EN 80079-36:2016. The actual surface temperature of non-electrical equipment is depended on the process and ambient conditions (EN 80079-36:2016 § 6.2.5 and 6.2.7). The protection from high or low temperature must be considered by the end user before put into service.

The product does not possess any residual risk according to hazard analysis conducted under the applicable directives providing that the procedures stated by the IMO are followed and the product is used under conditions mentioned in the technical specifications.

Documents with digital and/or e-signature conveyed by Valmet Flow Control conform to the Regulation (EU) No 910/2014 as well as the national code on e-signatures. In order to secure the integrity of the document, the authenticity of the sender, and indisputableness of the dispatch the identification is covered by individual ID codes, passwords, and by regularly changing passwords. The authorization to sign documents is based on organizational position and/or is task related. The impartial third party in the company bestows the access right with predefined authorities to particular databases.

Vantaa 10.9.2024

Juha Virolainen, Global Quality Director

13. TYPE CODE

Neles™ modular ball valve, series M1 and M2										
1.	2.	3.	4.	5.	6.	7.	8.	9.	10.	
	M1	M	A	150	A	P	V	A	/	-

1. sign	Low noise construction
Q-	Attenuator in flow port of ball

2. sign	Valve series, face-to-face length
M1	Full bore, seat supported, f-to-f length acc. to ISO 5752 basic series 3, 4, 12 or 15 depending on size and pressure class. Seat supported DN 025-300, trunnion mounted DN 250-600.
M2	Full bore, seat supported, f-to-f length acc. to ASME B16.10
M9	Face-to-Face acc. to P-series. Seat supported types for sizes: DN 100, 150, 200, 250 and 300. Trunnion mounted types for sizes: DN 350 and 600.

3. sign	Pressure rating of body and flanges
J	EN PN 10
K	EN PN 16
L	EN PN 25
M	EN PN 40
R	JIS 10K
S	JIS 16K
T	JIS 20K
C	ASME Class 150
D	ASME Class 300

4. sign	Construction
A	Standard construction, seat supported
W	Trunnion mounted, 2-seats
Z	Trunnion mounted, 1-seat *
P	Pocket Feeder (only sizes DN150 and DN200mm, EN PN10 and EN PN16)

5. sign	Size
Seat supported valves	025, 040, 050, 065, 080, 100, 125, 150, 200, 250, 300 (M1) 01, 1H, 02, 03, 04, 06, 08**, 10**, 12** (M2)
Trunnion mounted valves	250, 300, 350, 400, 450, 500, 600 (M1) 10, 12, 14, 16, 18, 20, 24 (M2)

6. sign	MATERIALS			
	Body material	Trim (and Coating) material	Stem material	Bolting material / thread
A	CF8M	CF8M (+ Hard Chrome, if metal seat)	AISI 329 trunnion mounted: XM-19 (DN250-600, 10"-24")	A2-70 (M1) B8M/8M (M2) /metric
C	CG8M	CG8M (+ Hard Chrome, if metal seat)	AISI 329 trunnion mounted: XM-19 (DN250-600, 10"-24")	A2-70 (M1) B8M/8M (M2) /metric
U	CK-3MCuN	CK-3MCuN (& Ceramic coating, if metal seat)	UNS S31254	A2-70 (M1) B8M/8M (M2) /metric
S*	CF8M + Cobalt based alloy sleeves in flow ports	CF8M (cobalt based coating on ball surface and flow port)	AISI 329 Only for Seat supported type	A2-70 (M1) B8M/8M (M2) /metric
X**	4A	4A (+ Hard Chrome, if metal seat)	AISI 329 trunnion mounted: XM-19 (DN250-600, 10"-24")	A2-70 (M1) B8M/8M (M2) /metric
Specials for POCKET FEEDER valves				
G (DN150,200)	G (DN150,200)	CF8M UNS S31803 & Tungsten chrome carbide (W/ Cr)C	XM-19	A2-70 (M1) B8M/8M (M2) / metric

* Material code "S", only for SEAT SUPPORTED types.

** Intended for erosive (black liquor) evaporation service with metal seats (V).

7. sign	MATERIALS			
	Seat type	Seat material	Bearing material	Back seal material
SEAT SUPPORTED (*)				
P	locked	SS + Cobalt based hard facing	PTFE + Graphite	PTFE
P1	locked	SS + Cobalt based hard facing	PTFE + Graphite	Graphite
X	soft	Xtreme®	PTFE + Graphite	-
T	soft	PTFE	PTFE + Graphite	-
S	unlocked	SS + Cobalt based hard facing	PTFE + Graphite	PTFE
E	low Δp	SS + Cobalt based hard facing	PTFE + Graphite	PTFE/FPM
C	locked	CK-3MCuN + Cobalt based hard facing	PTFE + Graphite	PTFE
V	locked	4A + Cobalt based hard facing	PTFE + Graphite	PTFE
M	soft	Filled PTFE	PTFE + Graphite	-
A (DN050,080)	locked/ forced	UNS S31803 + Cobalt based hard facing	PTFE + Graphite	Graphite and EPDM
B (DN150,200)	locked/ forced	UNS S31803 + Tungsten chrome carbide (W/Cr)C	Cobalt based alloy and SS steel	Graphite and Viton
TRUNNION MOUNTED				
S	metal	SS + Cobalt based hard facing	PTFE + Graphite	Viton GF
P	metal	SS + Cobalt based hard facing	PTFE + Graphite	FFKM
T	soft	PTFE + C25	PTFE + Graphite	-

Note: Sizes DN 25mm and 40mm, all bearing material PTFE

Note: P, P1, S, E seat can only be combined with austenitic body (A, C; sign 6). V seat can only be combined with X (sign 6.) & C seat can only be combined with U (sign 6.).

8. sign	Packing	Body gasket
V	PTFE V-rings,	PTFE
F	Graphite	Graphite
M	Modified PTFE V-ring (*)	PTFE
G	Live loaded graphite packing	Graphite
T	Live loaded PTFE packing for	PTFE

(*) for high cycle applications in liquor service having tendency for built-up and mechanical packing wear.

9. sign	Model code
A	Version

10. sign	End connection style
Standard, without sign	EN 1092-1 Type B1 (Ra 3.2 - 12.5), standard, without sign (M1) ASME B16.5 0.06" raised face with Ra 3.2 - 6.3 μm, Ra 125 - 250 μin (M2)
12	ASME B16.5 Large male (M2)
13	ASME B16.5 Large female (M2)
23	EN 1092-1 Type C Tongue (M1)
24	EN 1092-1 Type D Groove (M1)
25	EN 1092-1 Type E Spigot (M1)
26	EN 1092-1 Type F Recess (M1)

*) flow direction indicated by an arrow on the body

** Class 300 body f-to-f acc. to ASME B16.10, table 2, short pattern

Note: M2-series.

Seat supported, NPS 01"-06", cl. 150/300, acc. to B16.10, long pattern

Seat supported, NPS 08"-12", cl. 150, acc. to B16.10, table 1, long pattern

Seat supported, NPS 08"-12", cl. 300, acc. to B16.10, table 2, short pattern

Trunnion mounted, NPS 10"-24", cl. 150/300, acc. to B16.10 long pattern

14. GENERAL SAFETY WARNINGS AND DISCLAIMERS

General safety warnings

Lifting

1. Always use a lifting plan created by a qualified person to lift this equipment. Lifting guidance is provided in this IMO (Installation, Maintenance and Operation manual) to assist in lifting plan development. Think about the center of gravity (CG) of the equipment being lifted. Make sure the CG is always under the central lifting point.
2. Valves may be equipped with lifting threads on the body or on the flanges. These are intended to be used with the lifting plan.
3. Use only correct and approved lifting devices. Ensure that lifting devices and straps are securely attached to the equipment prior to lifting.
4. Check, that lifting devices are not damaged and in good condition with a valid check stamp prior to use.
5. Workers must be trained for lifting and handling valves.
6. Never lift an assembly by the instrumentation (solenoid, positioner, limit switch, etc.) or by the instrumentation piping. Straps and lifting devices should be fitted to prevent damage to instrumentation and instrumentation piping. Failure to follow the lifting guidance provided may result in damage and personal injury from falling objects.

Work activities on the valve

1. Wear your personal safety equipment. Personal safety equipment includes but is not limited to protective shoes, protective clothing, safety glasses, helmet, hearing protection and working gloves.
2. Always follow the local safety instructions in addition to the Valmet instructions. If Valmet instructions conflict with local safety instructions, stop work and contact Valmet for more information.
3. Before beginning service on the equipment, make sure that the actuator is disconnected from any kind of power source (pneumatic, hydraulic, and/or electric), and no stored energy is applied on the actuator (compressed spring, compressed air volumes, etc.). Do not attempt to remove a spring return actuator unless the stop screw is carrying the spring force.
4. Make sure that there is a LOTOTO (Lock Out / Tag Out / Try Out) procedure in place for the system in which the valve is installed and strictly follow it.
5. Always make sure that the pipeline is depressurized and in ambient temperature condition before maintenance work is started.
6. Keep hands and other body parts out of the flow port when the valve is being serviced and the actuator is connected to the valve. There is a high risk of serious injury to hands and/or fingers due to malfunction if the valve suddenly starts to operate.
7. Beware of Trim (Disc, Ball or Plug) movement even when the valve is disassembled. Trim may move simply due to the weight of the part or change in position of the valve. Keep hands or other body parts away from locations where they may be injured by movement of the trim. Do not leave objects near or in the valve port which may fall in and need to be retrieved.

General disclaimers

Receiving, handling and unpacking.

1. Respect the safety warnings above!
2. Valves are critical components for pipelines to control high pressure fluids and must therefore be handled with care.

3. Store valves and equipment in a dry and protected area until the equipment is installed.
4. Do not exceed the maximum storage temperatures given in the IMO (installation, maintenance, and operating instructions).
5. Keep the original packaging on the valve as long as possible to avoid environmental contamination by dust, water, dirt, etc.
6. Remove the valve endcaps just before mounting into the pipeline.
7. FOR YOUR SAFETY IT IS IMPORTANT TO FOLLOW THESE PRECAUTIONS BEFORE REMOVAL OF THE VALVE FROM THE PIPELINE OR ANY DISASSEMBLY:
 - Be sure you know what flow medium is in the pipeline. If there is any doubt, confirm with the proper supervisor.
 - Wear any personal protective equipment (PPE) required for working with the flow medium involved in addition to any other PPE normally required.
 - Depressurize the pipeline, bring to ambient temperature, and drain the pipeline flow medium.
 - Cycle the valve to relieve any residual pressure in the body cavity.
 - After removal but before disassembly, cycle the valve again until no evidence of trapped pressure remains.
 - The valves with offset shaft (Butterfly, eccentric rotary plug) have greater trim area on one side of the shaft. This will cause the valve to open when pressurized from the preferred direction without a locking handle or an actuator installed.
 - **WARNING: DO NOT PRESSURIZE THE ECCENTRIC VALVE WITHOUT A HANDLE OR AN ACTUATOR MOUNTED ON IT!**
 - **WARNING: DO NOT REMOVE A HANDLE OR AN ACTUATOR FROM AN ECCENTRIC VALVE WHILE PRESSURIZED!**
 - Before installing the eccentric valve in or remove it from the pipeline, cycle the valve closed. Eccentric valves must be in the closed position to bring the trim within the face to face of the valve. Failure to follow these instructions will cause damage to the valve and may result in personal injury.

Operating

8. The identification plate (ID-plate, type plate, nameplate, or engraved markings) on the valve gives the information of max. process conditions to the valve.
9. (For soft seats) The practical and safe use of this product is determined by both the temperature and pressure ratings of the seat and body. Read the identification plate and check both ratings. This product is available with a variety of seat materials. Some seat materials have pressure ratings that are lower than the body ratings. All body and seat ratings are dependent on the valve type, size and material of the body and seat. Never exceed the marked rating.
10. Temperatures and pressures must never exceed values marked on the valve. Exceeding these values may cause uncontrolled release of pressure and process medium. Damage or personal injury may result.
11. The operating torque of the valve may rise over time due to wear, particles or other damage of the seat. Never exceed the actuator torque preset values (air supply, position). Application of excessive torque may cause damage to the valve.
12. Valmet valves typically are designed to be used in atmospheric conditions. Do not use valves under external pressurized conditions unless specifically designed and explicitly marked for this service.

13. Avoid Pressure shocks or water hammer. Systems with high pressure valves should be equipped with a bypass to reduce the differential pressure before opening the valve to avoid pressure shock.
14. Avoid thermal shock. High temperature, Low temperature and cryogenic valves should be operated in a way that limits the rate of increase or decrease in temperature. The valve should be thermally stabilized before being pressurized.
15. Materials of the valve are carefully selected for the process conditions. Changes to the process media can have a major impact on function and safety of the valve. Always confirm the materials are suitable for the service prior to installation.
16. As the use of the valve is application specific, several factors should be considered when selecting a valve for a given application. Therefore, some situations in which the valves are used are outside the scope of this manual.
17. It is the end user's responsibility to confirm compatibility of the valve materials with the intended service, however if you have questions concerning the use, application, or compatibility of the valve for the intended service, contact Valmet for more information.
18. Never use a valve with enriched or pure oxygen if the valve is not explicitly designed and cleaned for oxygen. Selected materials and design have a major impact on the safety to operate the valve with oxygen.
19. Valves intended for use in or with explosive atmospheres must be equipped with a grounding device and marked according ATEX (or equivalent international standards).
20. Manual handles are available for specific butterfly valve sizes and maximum line pressures. Do not operate a valve with a handle or wrench outside the size and pressure limits stated in the IMO. High line pressure may create a large enough force to pull the handle from the operator's hands. Damage or personal injury may result.
29. Do not use sharp tools, grinding machines, or files to work on functional surfaces such as sealing, seating or bearing surfaces as this can damage these surfaces.
30. Check the condition of sealing surfaces on the seats, trim (disc, ball, plug, etc.), body and body cap. Replace parts if there are significant wear, scratches, or damage.
31. Check the wear of bearings and bearing contact surfaces on the shaft and replace damaged parts if necessary.
32. Do not weld on pressure retaining parts without an ASME and PED qualified procedure and personnel.
33. Pressure retaining parts of valves in high temperature applications must be carefully examined for the effects of material creep and fatigue.
34. Make sure that the valve is positioned in the correct flow direction into the pipeline.
35. If the valves are marked to be suitable for explosive atmospheres, the correct function of the discharging device must be tested before returning to service.
36. Always work in a clean environment. Avoid getting particles inside the valve due to machining, grinding, or welding nearby.
37. Never store a valve in maintenance without flow port protection.
38. When pressure testing valve seats, never exceed the maximum operating pressure of the system or the maximum shut-off pressure marked on the valve identification plate.
39. Actuator mounting and unmounting:
 - Before installing the actuator on to the valve, be sure the actuator is properly indicating the valve position. Failure to assemble these to indicate correct valve position may result in damage or personal injury.
 - When installing or removing a linkage kit, best practice is to remove the entire linkage assembly, including couplings which may fall off the valve during lifting or when position changes.
 - Mounting sets have been designed to support the weight of the Valmet actuator and recommended accessories either as is or with additional actuator support. Use of the linkage to support additional equipment or additional weight such as people, ladders, etc. may result in equipment damage or personal injury.

Maintenance

21. Respect the safety warnings above!
22. Plan service and maintenance actions, that spare parts, lifting devices and service personnel is available.
23. Maintain the valve within the recommended minimum maintenance intervals or within the recommended maximum operating cycles.
24. Always make sure that the valve and the pipeline is depressurized before starting any kind of maintenance work at a valve.
25. Always check the position of the valve before starting maintenance work. Follow the Lock out /tag out (LOTO) rules at the site before starting any maintenance activity.
 - See IMO for the correct stem position.
 - Consider that the positioner may give the wrong signals.
26. Sealing materials (soft sealing parts) should be changed when the valve is in maintenance. Always use original equipment manufacturers (OEM) spare parts to ensure proper performance of the repaired valve.
27. All pressure containing parts must be inspected visually for damage or corrosion. Damaged parts must be replaced.
28. Valve pressure retaining parts and all internals must be inspected for corrosion or erosion which may result in reduced wall thickness on pressure retaining parts. Damaged pressure retaining parts must be replaced with original equipment manufacturer's (OEM) replacement parts or repaired to factory specifications by an authorized Valmet service partner in order to maintain the warranty.
40. The valve should be installed between flanges using appropriate gaskets and fasteners that are compatible with the application, and in compliance with applicable piping codes and standards. Center the gaskets carefully when fitting the valve between the flanges. Do not attempt to correct pipeline misalignment by means of the flange bolting.
41. Repairs on valves for special service like Oxygen, Chlorine, and Peroxide, have special requirements.
 - Parts must be cleaned appropriate to the service and protected from contamination prior to assembly.
 - Assembly areas and tools must be clean and dry to prevent contamination of the parts during assembly.
 - Test equipment must be clean and dry to prevent contamination during testing. This includes the test equipment internals that may allow particles or other contamination into the test medium during the test.
 - Lubrication shall be used only if specifically required in the instructions. Where lubrication is required, the lubricant must be approved for the service by the end user.

Valmet Flow Control Oy

Vanha Porvoontie 229, 01380 Vantaa, Finland.

Tel. +358 10 417 5000.

www.valmet.com/flowcontrol

Subject to change without prior notice.

Neles, Neles Easyflow, Jamesbury, Stonel, Valvcon and Flowrox, and certain other trademarks, are either registered trademarks or trademarks of Valmet Oyj or its subsidiaries in the United States and/or in other countries.

