

## Steam and condensate system

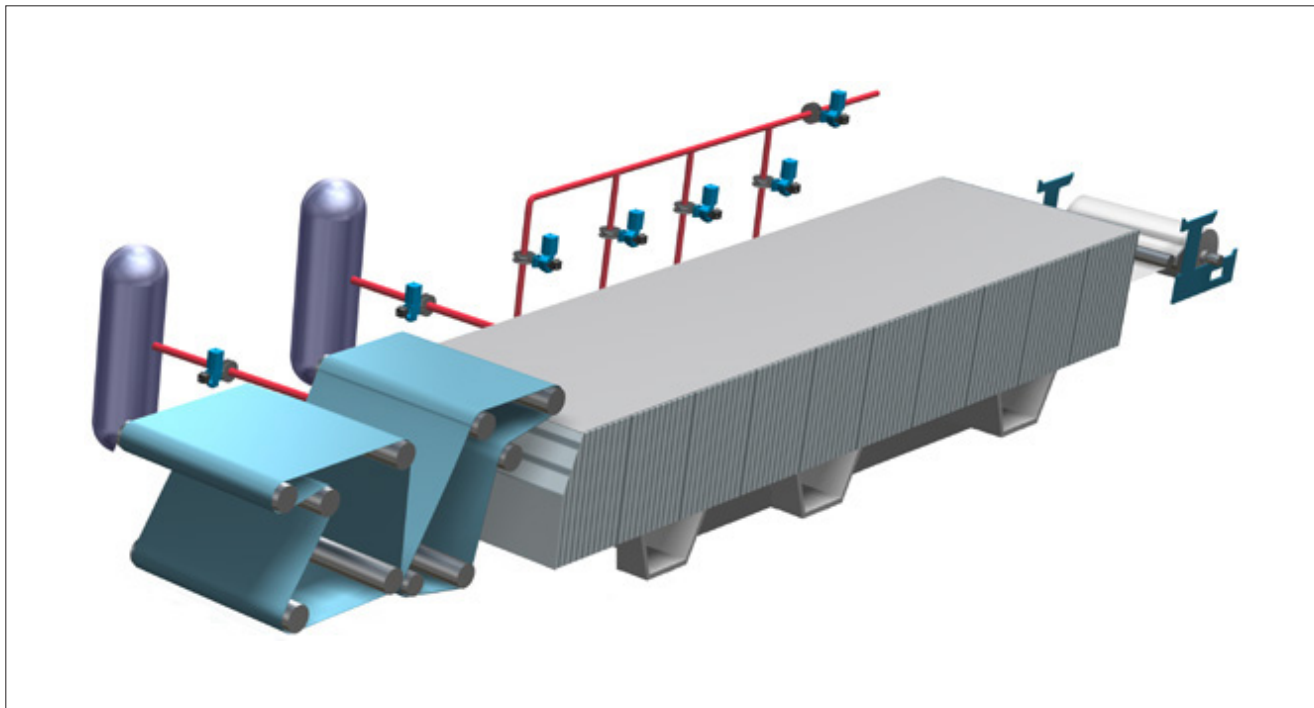

### Overview of the process

The objective of the steam and condensate system in the paper machine is to provide the steam for the drying. In the dryer part the moisture is evaporated as the sheet is pressed between a fabric and the hot drying cylinder.

#### The process

The steam and condensate system is a part of a paper machine. Past the press section, the paper sheet has a water content of about 60 %. The final drying is achieved in the drying section. This is achieved by means of several steam heated dryers (cylinders). These are driven in groups of few together. The paper sheet runs over a large number of dryers.

The temperature of each of the dryer surfaces must be exactly controlled. In the first group this might be 70 °C (160 °F) and rise then slowly to 105 °C (220 °F) in the later groups at the dry end.

#### Results

In the dryer the incoming steam turns partly to condensate. The differential pressure over the dryer is the main figure in the system design. This must be maintained to evacuate the condensate in a proper manner and amount. The condensate rate must be in balance with the amount of the “blow-through” steam flow. The “blow-through” steam is normally used in the cylinders of lower temperature.

## Typical process data

### Principles of the drainage

As shown in Figure 1, the drying cylinder has certain drainage elements: joints and siphons. The siphon can be stationary or rotating.

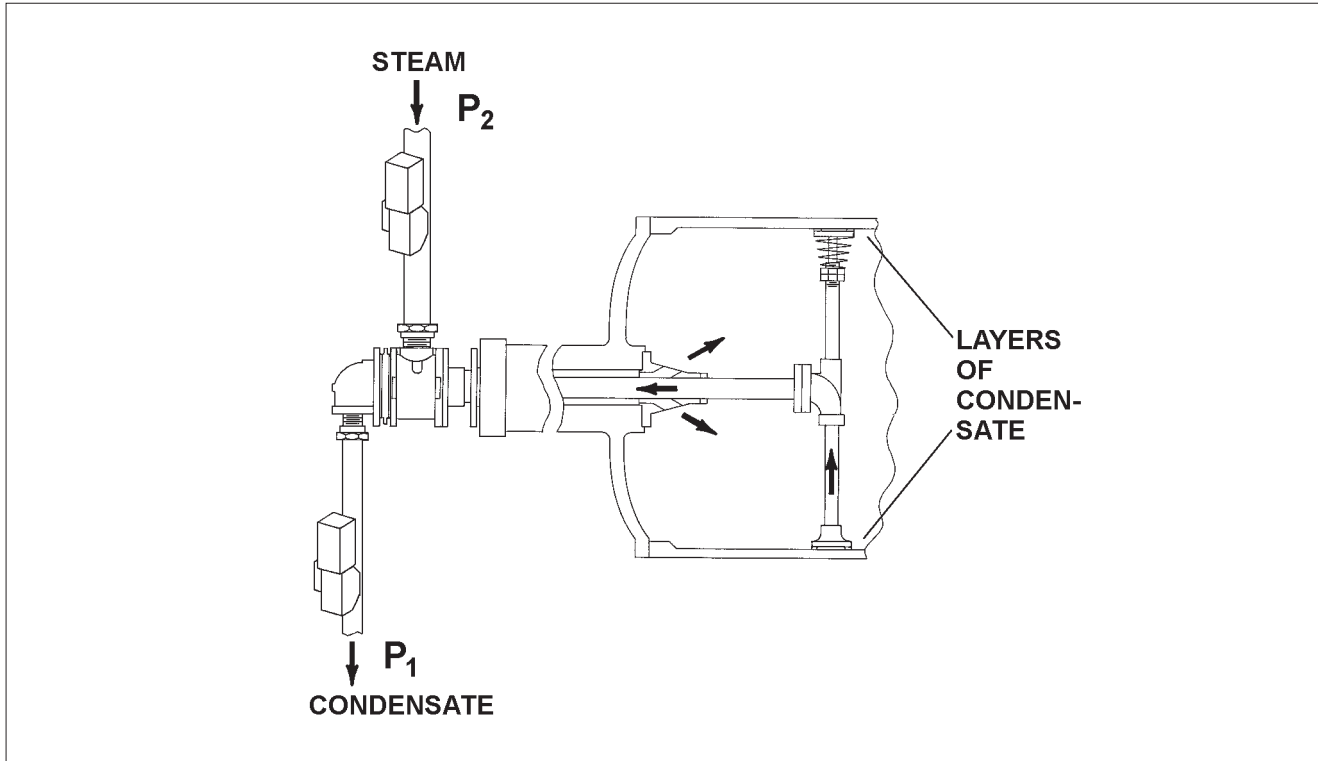

Fig. 1. The dryer siphon assembly, inside of the cylinder, with the supply and inlet piping and the outlet piping.

Typical approx. pressures and differentials for an example machine with 1200 m/min (4000 ft/min) compared in each group are:

	Group			
	1st	2nd	3rd	4th
Inlet header, bar (psi)				
Stationary	0.4 (5.7)	1.1 (16.4)	1.9 (27.1)	2.6 (37.8)
Rotating	0.8 (11.6)	2.0 (28.3)	3.1 (45.0)	4.2 (61.6)
Outlet header, bar (psi)				
Stationary	0 (0)	0.7 (10.7)	1.5 (21.5)	2.2 (32.2)
Rotating	0 (0)	1.1 (16.7)	2.3 (33.4)	3.4 (50.0)
Differential pressure				
Stationary	0.4 (5.7)	0.4 (5.7)	0.4 (5.7)	0.4 (5.7)
Rotating	0.8 (11.6)	0.8 (11.6)	0.8 (11.6)	0.8 (11.6)
Machine speed = 1200 m/min (4000 ft/min) Condensing load = 4400 lb/h				

## Control valves installed

The steam and condensate system design is based on the paper sheet weight and the machine configuration by the machine manufacturer.

The attached flow sheet (Figure 2) shows a simplified cascade system. The control valve PIC-1 gives a certain inlet header pressure (temperature).

The valves PIC-2 and PDIC-3 take care of the pressure control and pressure differential in this dryer group (of several cylinders).

From the condensate tank (separator) the blow through steam is fed to the inlet side of the valve PIC-2. The removal of condensate from the separators by means of pumps require level control valves (LIC). Raw water is used to cool down (to condensate/TIC) all excessive steam.

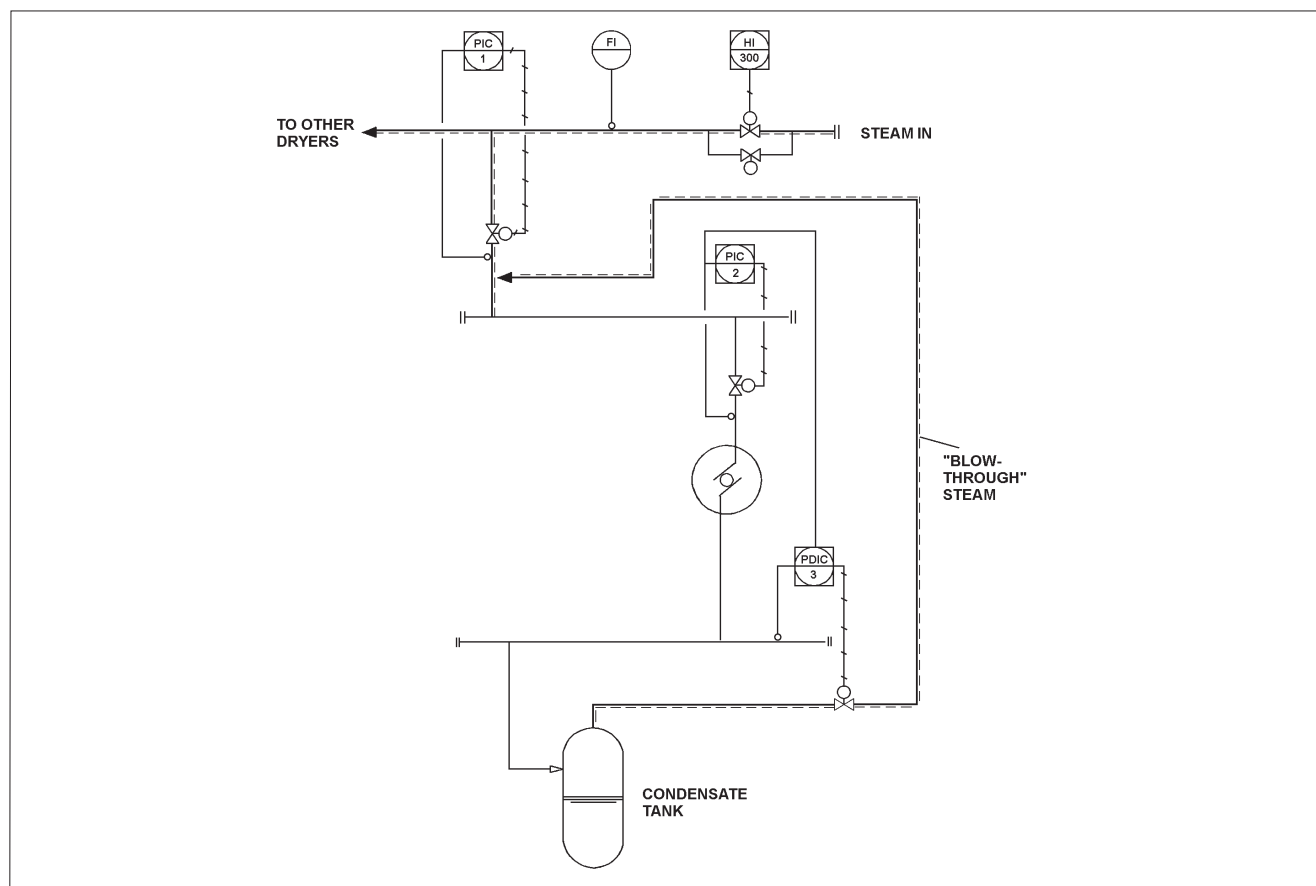

Fig. 2. Simplified flow sheet

## Considerations

Due to elevated temperatures metal seated valves are used in this process. The valves used should provide certain minimum tightness levels. The steam valves have to close as the paper sheet brakes or for other short shut down reasons. Elevated temperature in the dryers may damage the fabrics. The collection of condensate harms the re-start and causes problems to the machine drives.

The valves in the condensate side must open in a case of paper sheet brake. Spring to open type actuators are used here.

If the paper machine is to produce only one bulk paper grade, no big adjustments of the steam flow have to be made. Here a butterfly type valve can be successfully used as the control element if the system design data is calculated solid.

The basis weight and the steam consumption of the board machines must be changed often in large increments during the operation. The valves used for control purposes must provide a good controllability (rangeability).

V-shaped segment type valves are used commonly. Calculate the noise generation in case of elevated pressures. Q-Trims are used frequently.

**Valmet Flow Control Oy**

Vanha Porvoontie 229, 01380 Vantaa, Finland.

Tel. +358 10 417 5000.

[www.valmet.com/flowcontrol](http://www.valmet.com/flowcontrol)

Subject to change without prior notice.

Neles, Neles Easyflow, Jamesbury, Stonel, Valvcon and Flowrox, and certain other trademarks, are either registered trademarks or trademarks of Valmet Oyj or its subsidiaries in the United States and/or in other countries.

For more information [www.neles.com/trademarks](http://www.neles.com/trademarks)

