

Valves for coating kitchens and surface sizing

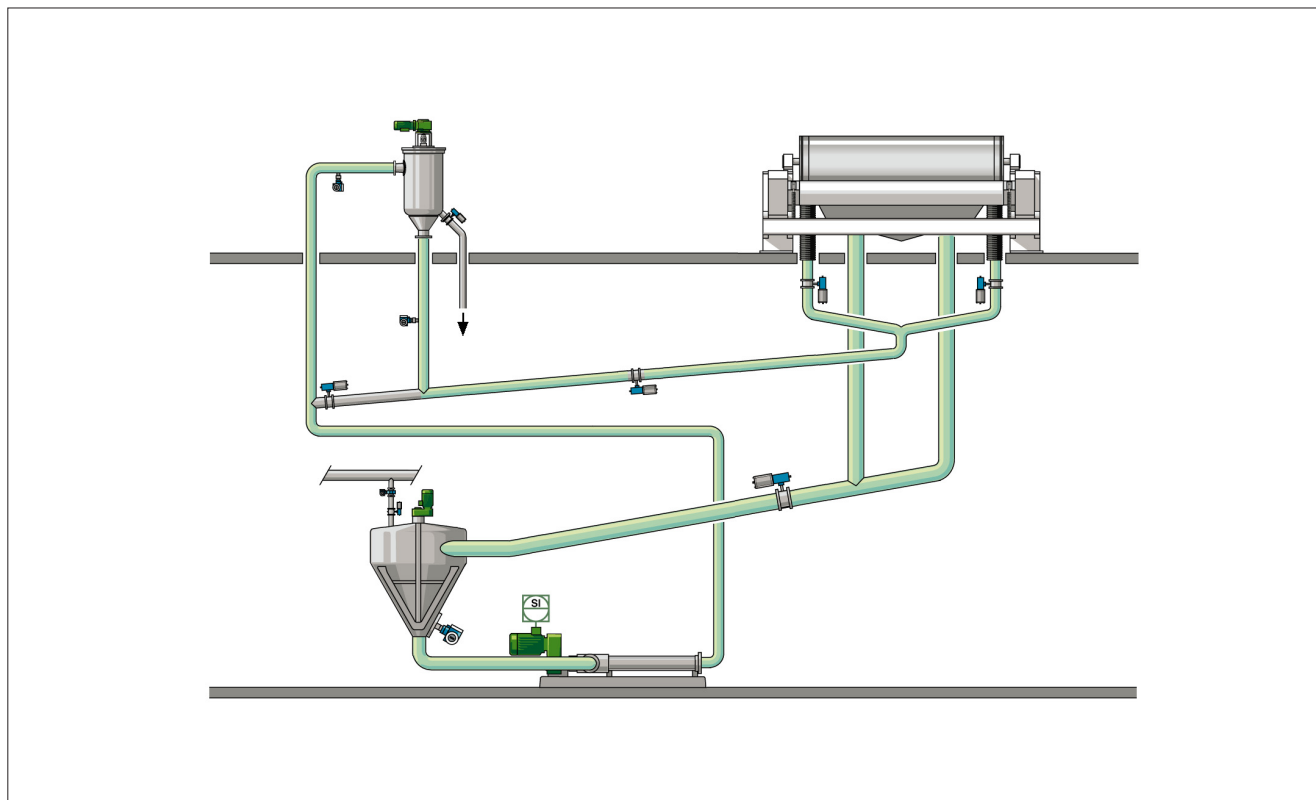

Overview of process

Different paper and board grades are coated. The coating treatment provides good surface and other physical properties of the paper sheet. There are two different treatment methods: coating and surface sizing. Surface sizing typically is used to fill in the unevenness of the surface, where coating refers to heavier mineral pigment layer. The coating is applied in an on-machine or off-machine process.

The coating slurry is prepared by mixing pigments, binding agents and additives. Also the additive plants for surface sized (treated) paper have similar plant sections and equipment.

Subprocesses

The coating slurry (colour) preparation takes place in the automated coating kitchen. Here the raw materials, such as starch, pigments and other additives are mixed. Careful dosing is computer controlled after the components are weighed. Most pigments require make-down units before their mixing. The application of sizing or coating can be made as an on-machine or off-machine operation.

The process

Make-down process

Different pigments like clay, titanium dioxide and calcium carbonate are normally processed in a make-down system prior to mixing. Figure 1 shows a schematic lay-out for the slurry make-down by ratio control. Other systems are based on density measurement to achieve a desired dilution of the slurry.

Starch preparation

Starch is prepared in a starch cooker. The Figure 2 shows a continuous starch cooking plant. The starch is first mixed with cold water. Steam and starch are fed to a cooker. LP-steam is used in the cooker in order to keep the cooking temperature constant.

After a flash tank the starch is diluted to desired viscosity and then stored in a tank before pumping it to the mixing process.

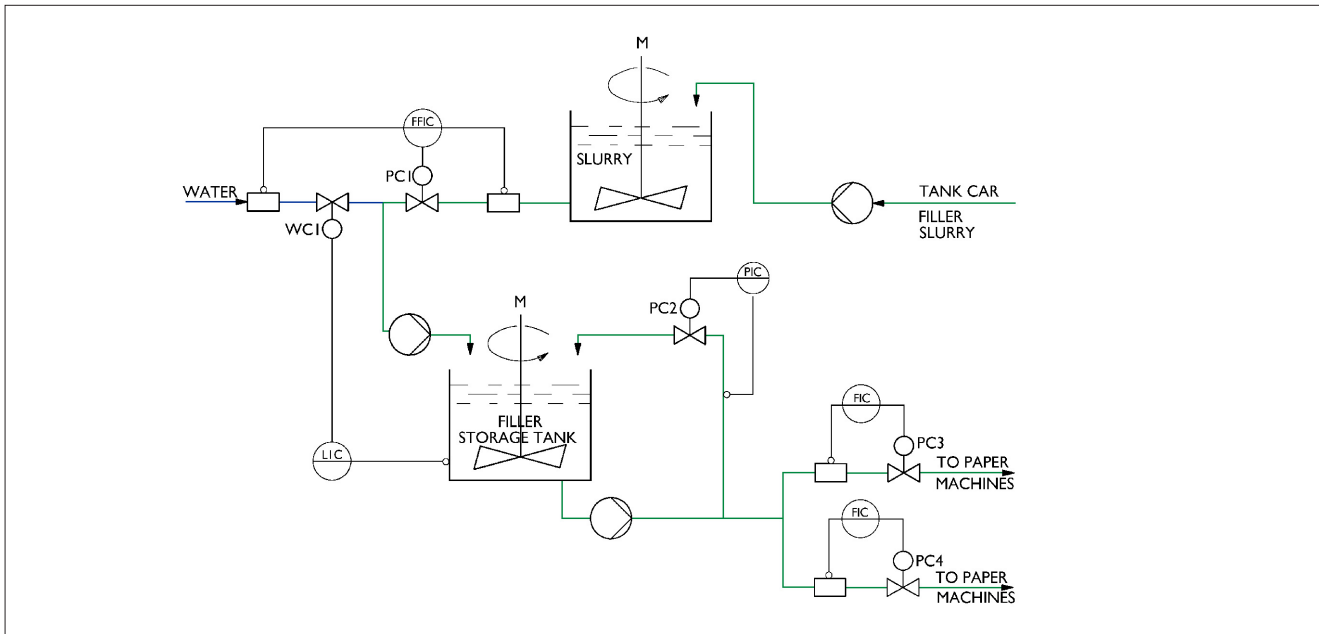

Fig. 1. Schematic lay-out for the slurry.

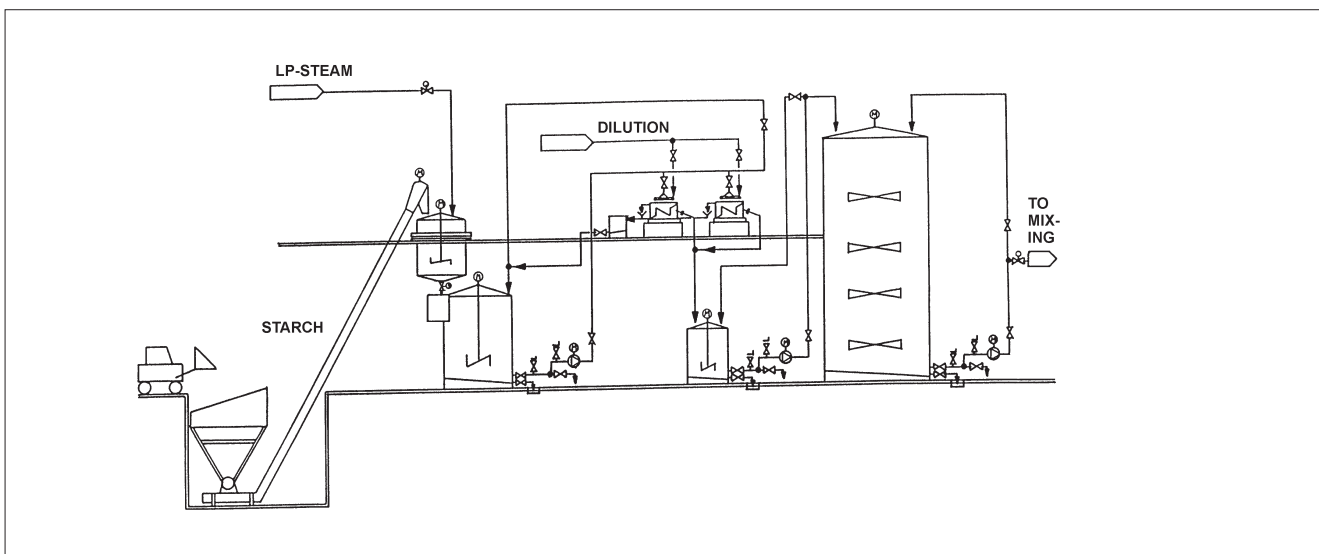

Fig. 2. Continuous starch cooking plant.

Mixing process

The components of a coating mixture vary greatly in their characteristics. They are stored separately in the right proportions prior to the mixing. Automated mixing can follow in a batch type or in a continuous process. Dosing, weighing or metering devices are used to control the process. Figure 3 shows one sample sequence for batch type coating preparation.

Coating slurry feed

From the coating kitchen, the coating colour is pumped to the coater or to the paper machine. Different application techniques are used. The piping arrangement is similar in all methods, and it is called the machine circulation. A certain portion of the coating is recirculated to be used again. Figure 4 shows a surface sizing unit.

Valve requirements

The pigments (clays) used in the coating slurry are very abrasive. Common problems for the process valves are:

- high erosion caused by the slurry with high flow velocities
- jamming of valves in case the slurry dries out in pipelines and forms buildup in the valves.

In these conditions essential valve characteristics include tight shut-off and control performance. They should be easily operable for long periods between maintenance shut-downs. Some systems include automated ball cleaning systems and here only full bore ball valves are accepted.

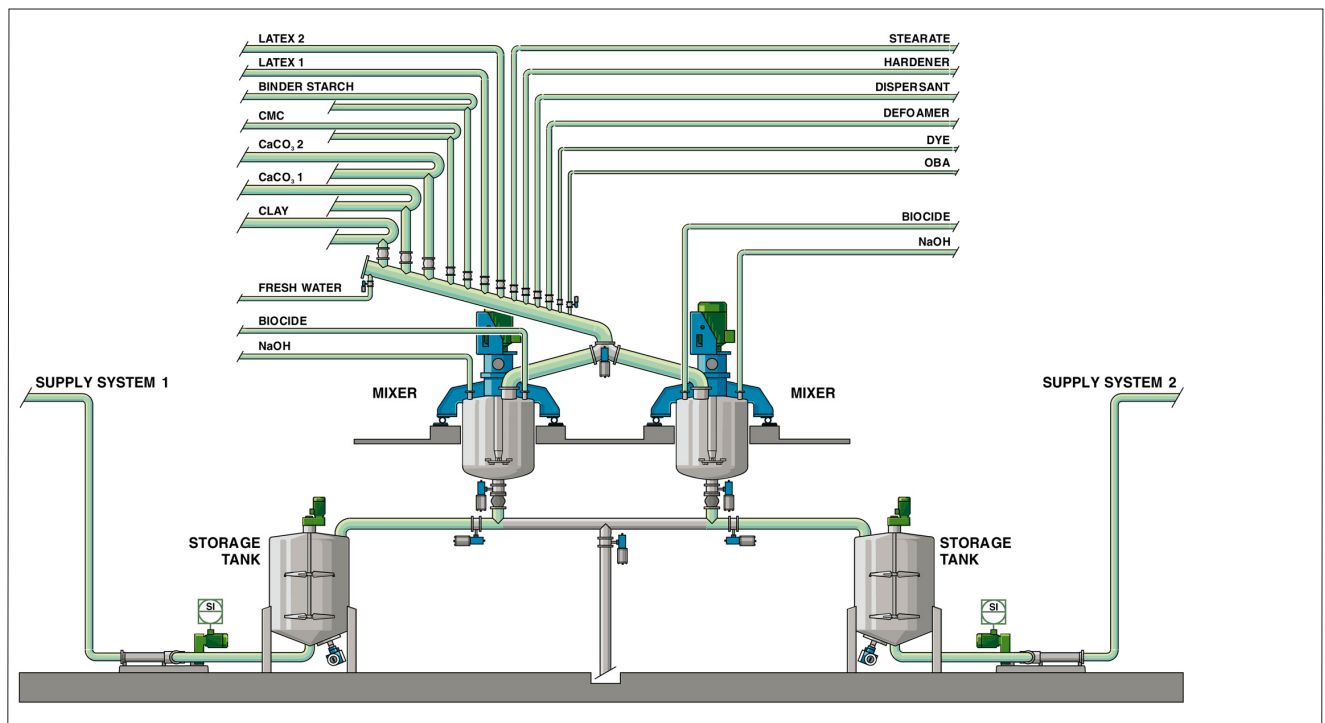

Fig. 3. Batch type coating preparation.

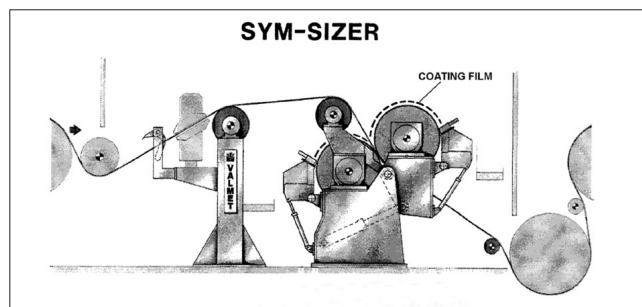

Fig. 4. SYM-SIZER surface sizing unit.

Figure 5 shows a simplified on-machine coating loop. The coating passes screens installed in the system. Hot water is used to wash the lines once the coating process is stopped. The valves FIC-5 and FIC-6 control the flow of the surface sizing slurry to the application unit. The size screens remove any accumulation of particles. The valve FHKS-2 is used to dump the reject from the sizing loop.

Valve selection

Depending on the pipe size and application the valves used can be ball, segment or butterfly valves. For the screen reject service Valmet can offer are “Pocket type” ball valve (FHKS-2) that turns 180 degrees to dump the accumulation. Adherent buildup on the surfaces causes wear on the valve seats. In these conditions valve seats having scraping action perform well. Neles’ ball and ball segment valves are available with scraping seats. The seat type code P gives this option. In case tight sealing is required, the seats should carry spring elements to give positive loading against the ball surface.

Another possibility is to apply soft seat materials and prepare for scheduled maintenance and replacement of the seats.

Neldisc™ triple eccentric disc valves have been successful in the machine circulation loop and other positions in some mills.

In applications, where a control valve wears quickly, we recommend the use of ceramic valve interiors. Valmet has developed a design utilizing solid zirconia ceramic ball and liners. This is the only ceramic material that has the required strength performance for torque transmission in cases when slurry dries inside the valve. The ball valve type E provides superior protection against erosion.

Valmet has a list of many successful installations in the coating slurry control application

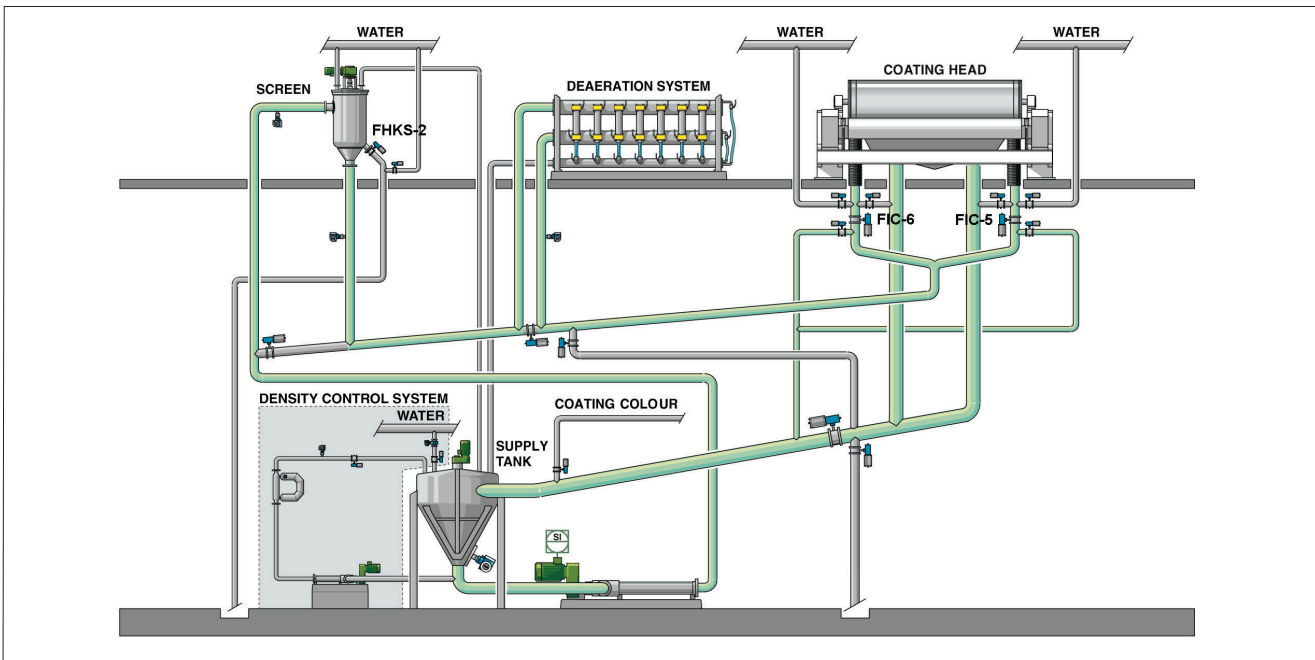

Fig. 5. On-machine coating loop.

Subject to change without prior notice.

Neles, Neles Easyflow, Jamesbury, Stonel, Valcon and Flowrox, and certain other trademarks, are either registered trademarks or trademarks of Valmet Oyj or its subsidiaries in the United States and/or in other countries.

For more information www.neles.com/trademarks

Valmet Flow Control Oy

Vanha Porvoontie 229, 01380 Vantaa, Finland.

Tel. +358 10 417 5000.

www.valmet.com/flowcontrol

