

Secondary fiber preparation - Deinking line

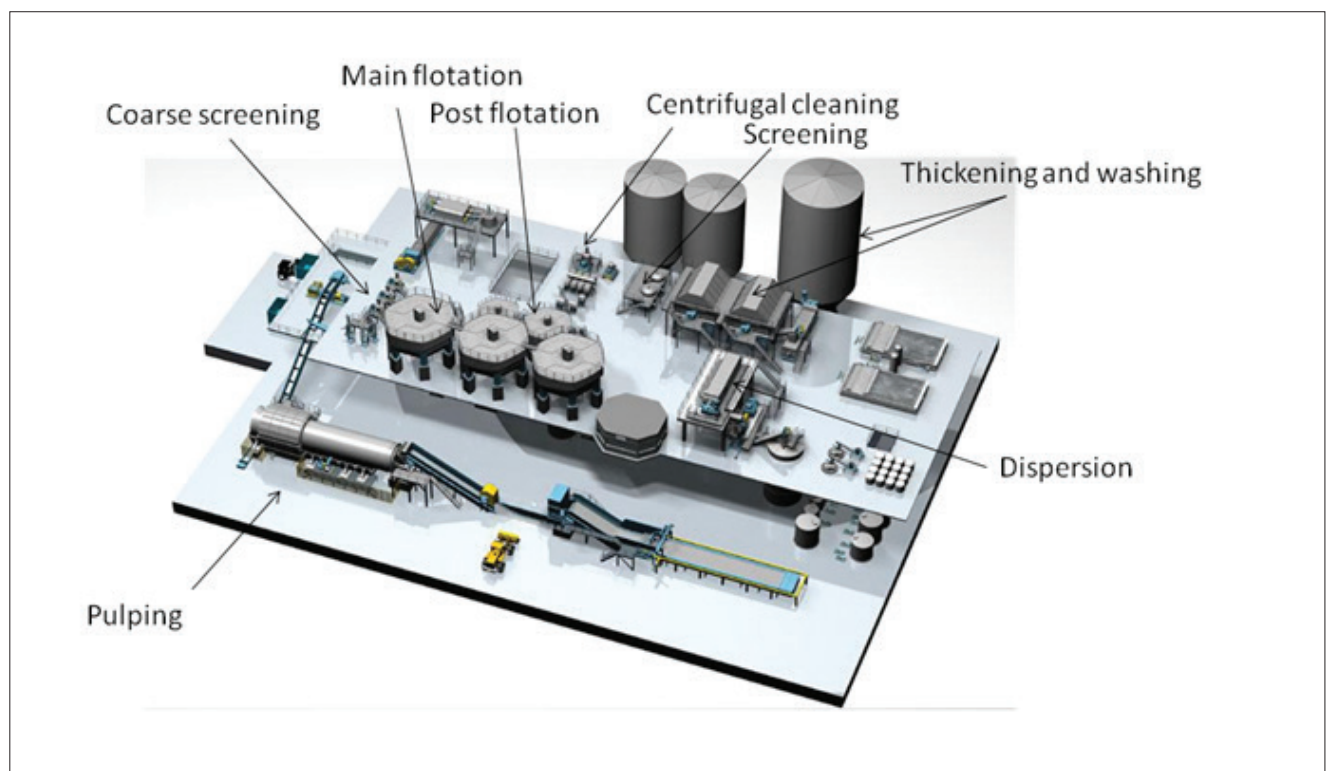

Introduction

More than half of the raw materials used by the world's board and paper industry is waste paper. This illustrates the great importance of waste paper to the paper industry.

Presumably, waste paper will play an even more important role in the future, affected by legislation, regulations and general opinion.

The goal in processing waste paper is to restore the original properties of the paper fiber and remove any impurities.

A single fiber can be recycled 3-5 times. The fiber shortens after each use, thus depreciating its value as a raw material.

The efficiency of waste paper processing and quality of the final product depends on the quality of the raw material being used, the paper printing method and waste paper turnaround time.

The Process

The deinking process separates printing inks from fibers in flotation cells using chemicals and removes any impurities or adhesives ('stickies') by grading with a centrifugal cleaner and pressure screen. The process is made typically up of the following parts:

Pulping

Pulping equipment might include a high-consistency pulper, low-consistency pulper or drum pulper. The correct proportion of deinking chemicals and warm circulation water are added to the waste paper in the pulper or drum pulper section.

The length of the drum pulper can be 30 m, with a diameter of 2.5-4 m and a rotating speed of 100-120 meters per minute. The pulp is fed at a 14-20 % consistency together with deinking chemicals. In the screen section the pulp is diluted to a 3-5 % consistency using dilution water fed from overhead.

Batch pulpers can be designed for a range of batch pulping conditions at consistencies up to 17 % on a fiber material basis. The cycle time will depend on the grades of paper being re-pulped as well as the limitations of the auxiliary systems used to add water and pump out the pulper.

Dilution- and chemical valves in this area are segment- or butterfly valves depend on valve size. Pulp valves can be used segment valves

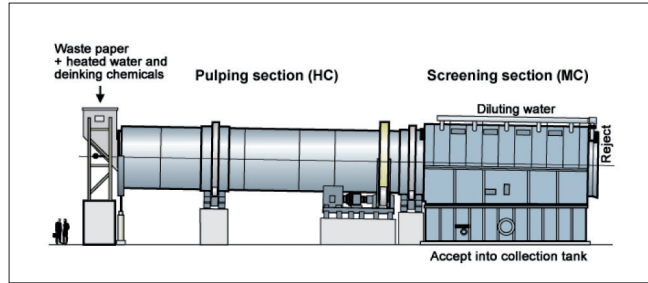

Drum pulper

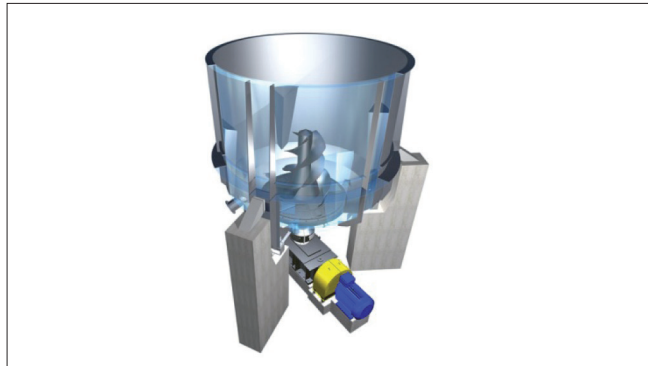

Batch pulper

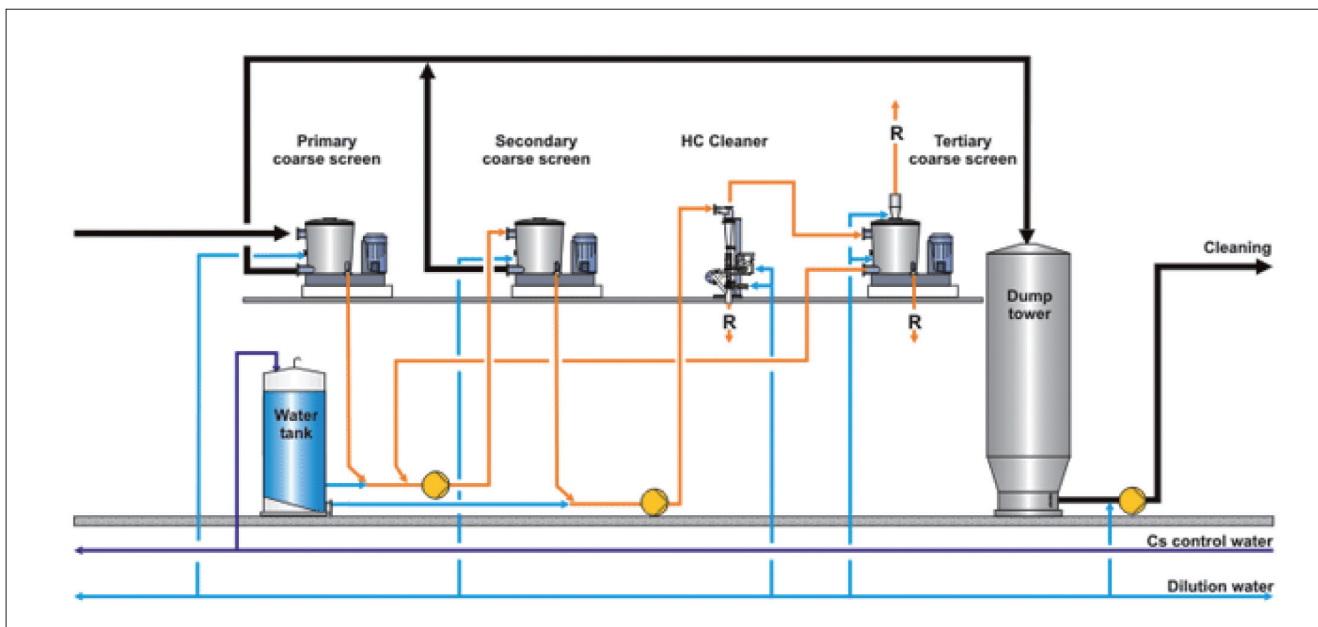

Coarse screening

The coarse screens are designed to remove heavy, light and coarse particles and contaminants in the recycled fiber process. Thus they also protect subsequent process equipment from potential damage by heavy and coarse particles.

The vertical screens, featuring a conical screen body and rotating screen cylinder and a centrifugal unit for removal lightweight rejects, operates typically in primary and secondary, but even in tertiary stages.

The vertical screen units operate in consistency range of 2.5-5 %.

Dilution- and chemical valves in this area are segment- or butterfly valves depend on valve size. Pulp valves can be used segment valves. Reject valves should be line size ball valves because of heavy impurities.

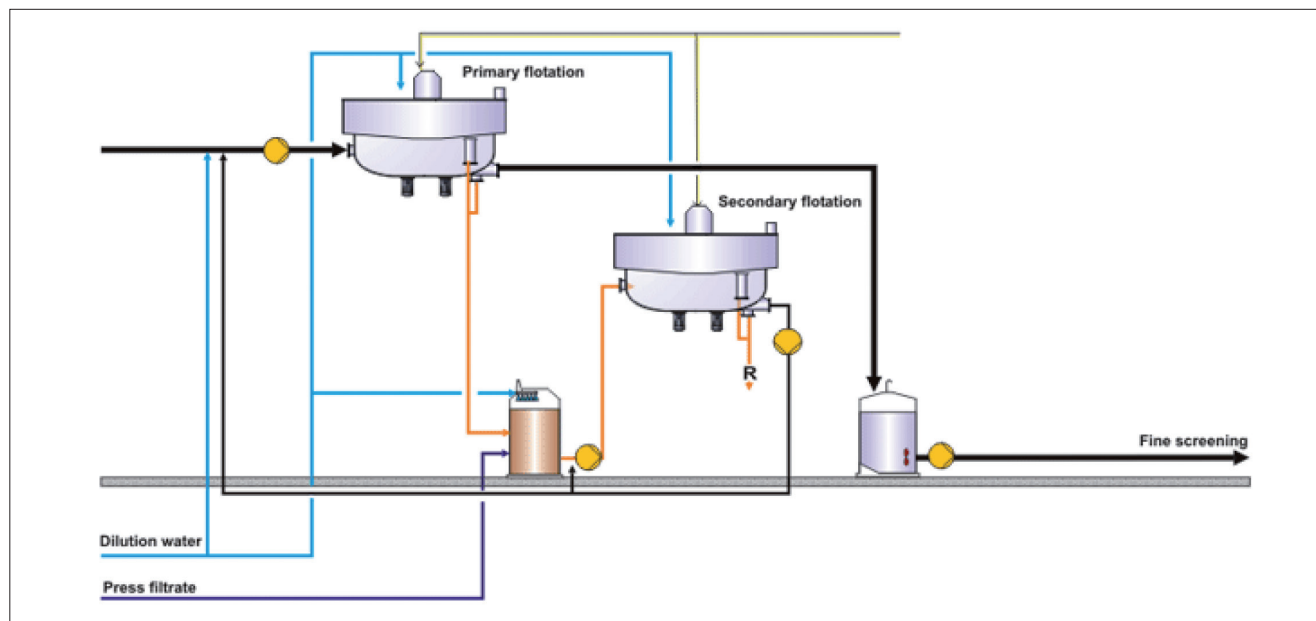

Main flotation

There are two methods used in the removal of printing inks: washing and flotation. Today, deinking is usually performed using the flotation method.

Flotation is a separation method which utilizes the divergent surface chemical properties of different particles. Pulps coming from prescreening with a consistency of 2-3 % are diluted to a 1-1.4 % flotation consistency. Air is injected into the diluted pulp slush, and printing ink particles that have become hydrophobic attach themselves to air bubbles and rise to the surface. The foam containing printing inks and impurities that forms at the surface can be removed by skimming, overflow or suction. After precipitation, printing ink slurry (generally 6-10 % of the incoming waste paper) can be incinerated either in a fluidized bed or bark boiler. Dilution- and chemical valves in this area are segment- or butterfly valves depend on valve size.

Cleaners and screening

Pulp coming from flotation is diluted to a 0.7-1 % centrifugal cleaning consistency. Using centrifugal force, small grains of sand, metal shavings and lumps of clay are ejected through the apertures found at the bottom of the cleaner. Also, in some models, lightweight impurities and air are ejected from the center of the centrifugal cleaner. Centrifugal cleaning is usually ordered according to the cascade principle, in which the accept is returned to the feed of the preceding phase and reject is pumped to the next phase. The number of phases and centrifugal cleaners depends on the mill production capacity and consistencies being used.

After the centrifugal cleaners, the pulp is pumped into pressure screens, which are usually slot screens (aperture size: 0.1-0.4 mm). Screens operate on a cascade connection or onward from the second phase accept. Screens remove small impurities, stickies and shives which the printing inks or fillers are still binding. Reject from the last phase of centrifugal cleaning and pressure screening is ejected from the process into deinking slurry or effluent channels.

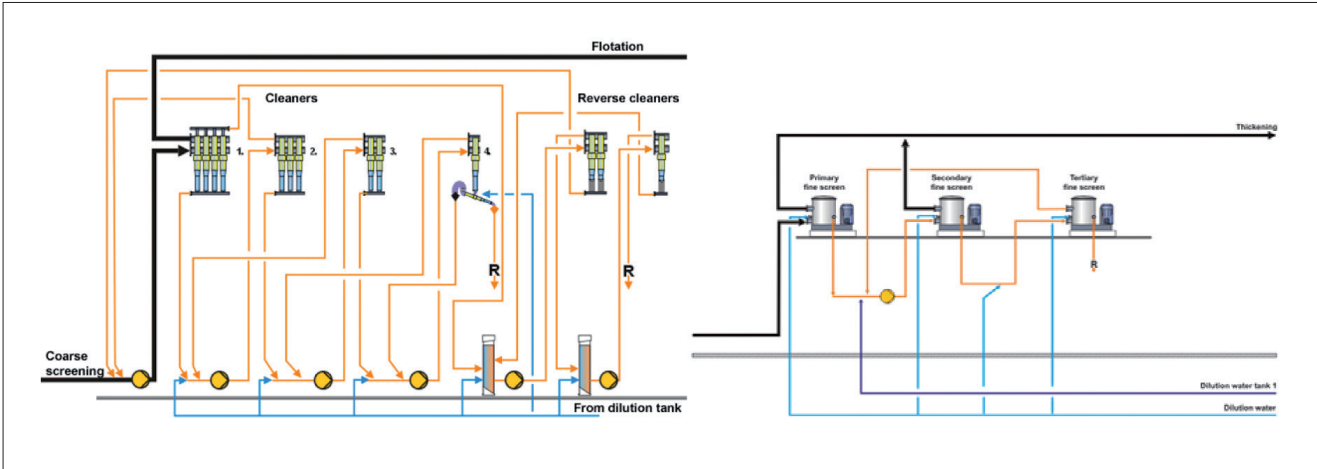

Valves in this area are segment-or butterfly valves depend on valve size.

Thickening and washing

The smallest impurities can be removed by washing the pulp in one or two phases. Washing can be included in the thickening phase, where all or a portion of the filtrates are ejected from the system. If filtrates are returned to the system, they can be cleaned using screens or flotation.

Disc filters, drum filters, gravity thickeners, gap washer thickeners , wire presses , screw presses, and roll presses are used in thickening. Thickening is most commonly performed using a disc filter, because it is the least expensive device proportional to the amount of water being ejected. The disc filter is ineffective as a washing device or ash remover. Formers, screw presses or drum filters are used for washing and ash removal.

Dilution valves in this area are segment-or butterfly valves depend on valve size. Disc filter feed valve could be segment valve and after thickening drop leg MC pump level control valve is MC-segment valve.

Thickening and clarification

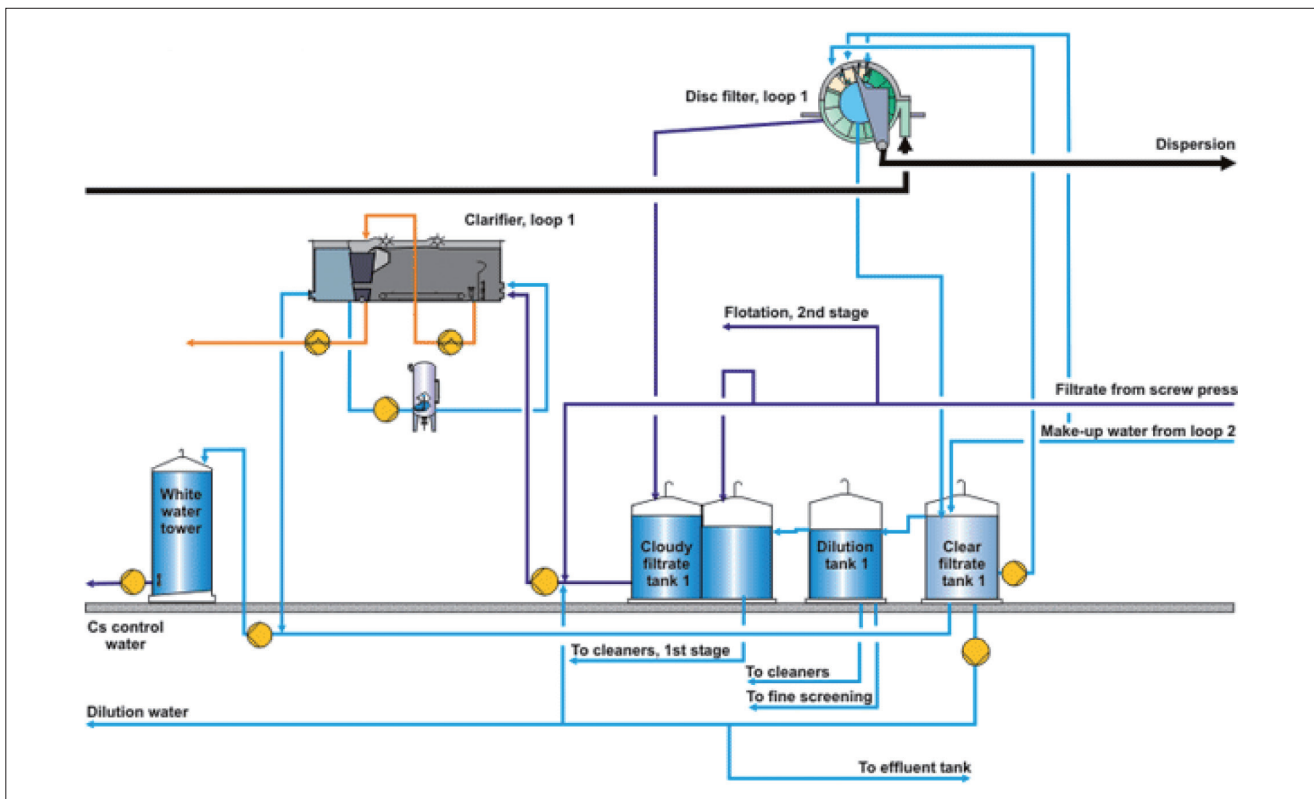

Dispersing

In dispersing the pulp is pressed to a consistency of approximately 30-35 % and conveyed with screw and steaming conveyors to the dispersing unit. In the steam screw, steam (80-120 °C) is injected into the pulp, thus sterilizing it and softening stickies.

Ink and stickies remaining after dispersing are broken down into pieces too small to be seen with the naked eye. As a result, the impurities are not eliminated, but hidden within the pulp. Various disc or cone refiner-type devices or kneaders are used in dispersing.

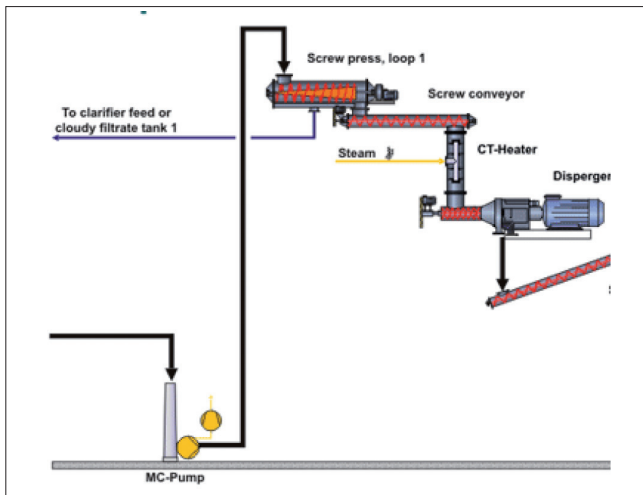

Dilution valves in this area are segment- or butterfly valves depend on valve size. Disperser outlet valve and drop leg level control valve could be segment- or MC segment valve.

Bleaching

After deinking, the final pulp brightness is approximately 60 units. Brightness can be further increased by bleaching around 10 units.

Recycled pulp is bleached in a variety of ways throughout the world. Bleaching is mainly done using hydrogen peroxide (H₂O₂). Another alternative is dithionite bleaching. The advantage of these bleaching agents is that they can be used in the bleaching of both mechanical and chemical pulps.

Dilution valves in this area are segment- or butterfly valves depend on valve size. Pulp lines segment valves in control and ball valves for on-off, peroxide valves must be degreasing.

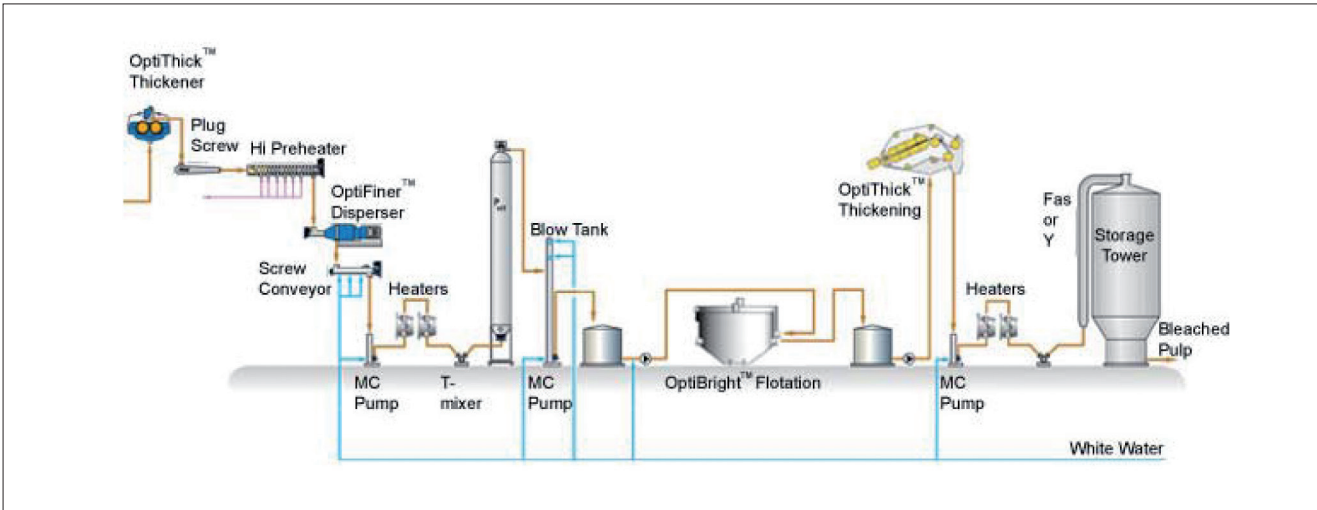

High-temperature peroxide bleaching

Post flotation

In post flotation small ink particles separated by dispersion in the stock is removed, along with some very lightweight contaminants and ash that passed through the previous stages. This is caused by a flotation deinking process, which operates at approximately 1,2 % consistency. Reject consistency varies depending on the running parameters and raw material variations.

Valve selection is same as in flotation.

Process parts could be in different order depend on waste paper grades and quality material and end product. Here is as example of 2-loop deinking line for newspaper:

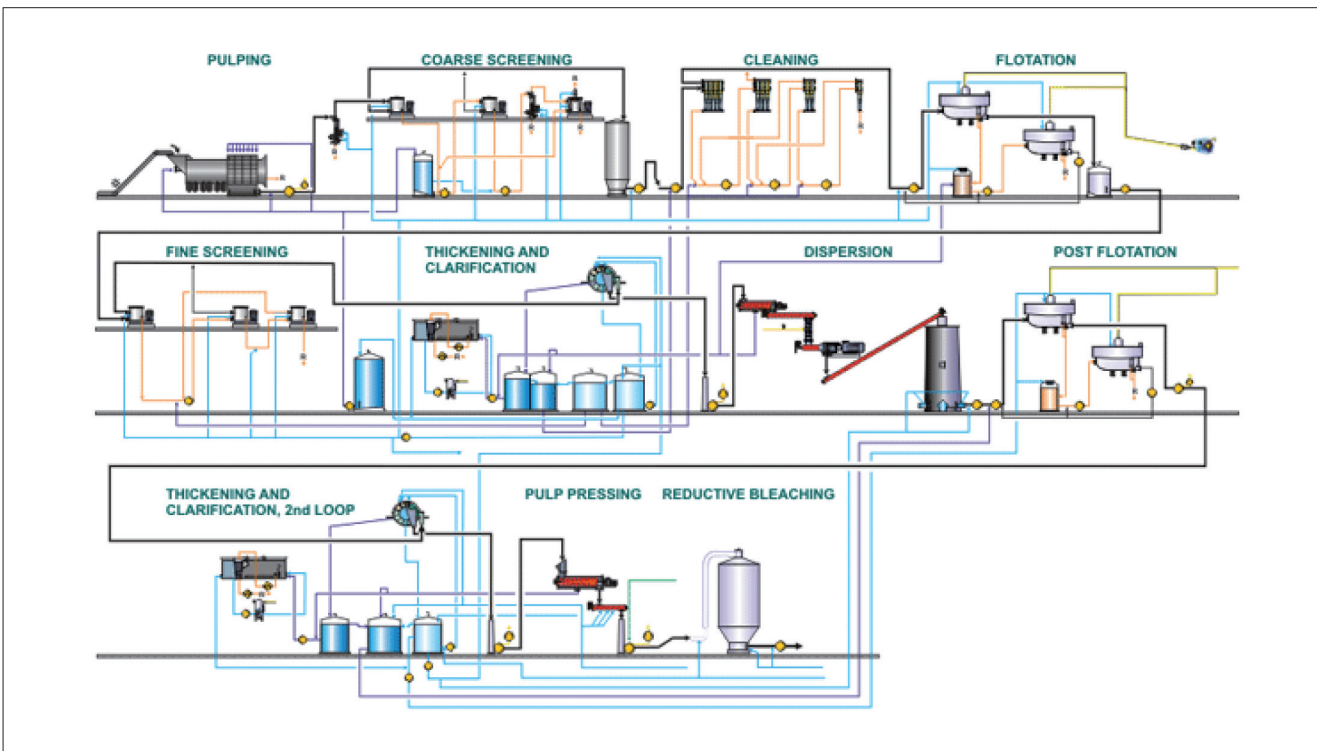

Valmet Flow Control Oy

Vanha Porvoontie 229, 01380 Vantaa, Finland.

Tel. +358 10 417 5000.

www.valmet.com/flowcontrol

Subject to change without prior notice.

Neles, Neles Easyflow, Jamesbury, Stonel, Valvcon and Flowrox, and certain other trademarks, are either registered trademarks or trademarks of Valmet Oyj or its subsidiaries in the United States and/or in other countries.

For more information www.neles.com/trademarks

