

Installation, operation and maintenance instructions for Flowrox™ Expulse™ Dampener DN32 - DN100

Installation, maintenance and operating instructions



These instructions must be read carefully and understood prior to the installation, use, and servicing of this product.

DISCLAIMER

ALL DRAWINGS, SPECIFICATIONS, DATA, SOFTWARE, FIRMWARE, MANUALS, INSTRUCTIONS, DOCUMENTATION OR OTHER WORKS OF AUTHORSHIP FURNISHED BY VALMET ARE COPYRIGHTED PROPERTY OF VALMET OR ITS SUPPLIERS, AND ARE TO BE USED BY CUSTOMER, PURCHASER, SUBCONTRACTOR, SUPPLIER OR OTHER AUTHORIZED PERSONS (“USERS”) ONLY FOR THE PURPOSE OF INSTALLING, OPERATING, MAINTAINING AND REPAIRING THE GOODS AND SERVICES SUPPLIED BY VALMET (“PRODUCTS”). SUCH WORKS AND DATA MAY NOT BE OTHERWISE USED OR REPRODUCED OR DISCLOSED. VALMET OR ITS SUPPLIERS RETAIN ALL RIGHT, TITLE AND INTEREST IN AND TO ITS AND THEIR INVENTIONS, DISCOVERIES, CONCEPTS, IDEAS OR OTHER INTELLECTUAL PROPERTY EMBODIED IN OR RELATED TO ITS PRODUCTS.

ANY AND ALL TRADE SECRETS, SPECIFICATIONS, DRAWINGS, DESIGNS, SOFTWARE, SAMPLES, OTHER TECHNICAL, FINANCIAL, PRODUCT, MARKETING, SALES, PRODUCTION, SUBCONTRACTING, PRICING AND OTHER CONFIDENTIAL AND/OR PROPRIETARY INFORMATION OF A PARTY PERTAINING TO THE PRODUCTS OR OTHERWISE TO THIS CONTRACT, OR TO A PARTY, ITS PRODUCTS, BUSINESSES, OPERATIONS, OR PLANS, SHALL NOT BE DISCLOSED TO ANY UNAUTHORIZED THIRD PARTY BY THE OTHER PARTY. THE RECEIVING PARTY SHALL ENSURE THAT ITS DIRECTORS, OFFICERS, EMPLOYEES AND AGENTS COMPLY WITH THE OBLIGATIONS HEREIN. UNLESS OTHERWISE AGREED TO IN WRITING BY THE PARTIES, THE PARTIES' CONFIDENTIALITY, NON-DISCLOSURE AND NON-USE OBLIGATIONS HEREIN SHALL REMAIN IN FORCE TO THE MAXIMUM TERM PERMITTED BY APPLICABLE LAW.

THIS MANUAL PROVIDES INSTRUCTIONS TO CARRY OUT CERTAIN ACTIVITIES AND IS DESIGNED AND MEANT TO GUIDE AND ASSIST PROFESSIONAL AND PROPERLY TRAINED EXPERTS IN PERFORMING THEIR FUNCTIONS. EVERYONE MUST BECOME FAMILIAR WITH ALL INSTRUCTIONS IN THIS MANUAL BEFORE ANY INSTALLATION, USE, MAINTENANCE, REPAIR OR ANY OTHER ACTIONS OF THE RESPECTIVE GOODS AND/OR SERVICES WHICH THIS MANUAL APPLIES TO. ALL INSTRUCTIONS MUST BE FOLLOWED CAREFULLY. HOWEVER, OBSERVANCE OF ANY PART OF THE INSTRUCTIONS PRESENTED IN THIS MANUAL MAY BE OMITTED IN EVENT WHEN IT IS REQUIRED OR ALLOWED BY LAW. VALMET HAS TAKEN EVERY CARE IN THE PREPARATION OF THE CONTENT OF THIS MANUAL, BUT DOES NOT MAKE ANY REPRESENTATIONS, WARRANTIES OR GUARANTEES OR, EXPRESS OR IMPLIED, AS TO THE ACCURACY OR COMPLETENESS OF THIS MANUAL.

ALL USERS MUST UNDERSTAND AND BE AWARE THAT UPDATES AND AMENDMENTS WILL BE MADE FROM TIME TO TIME TO THIS MANUAL. ALL USERS ARE OBLIGATED TO FIND OUT AND DETERMINE WHETHER THERE HAVE BEEN ANY APPLICABLE UPDATES OR AMENDMENTS TO THIS MANUAL. NEITHER VALMET NOR ANY OF ITS DIRECTORS, OFFICERS, EMPLOYEES, SUBCONTRACTORS, SUB-SUPPLIERS, REPRESENTATIVES OR AGENTS SHALL BE LIABLE IN CONTRACT, TORT OR IN ANY OTHER MANNER WHATSOEVER TO ANY PERSON FOR ANY LOSS, DAMAGE, INJURY, DEATH, LIABILITY, COST OR EXPENSE OF ANY NATURE, INCLUDING WITHOUT LIMITATION INDIRECT, INCIDENTAL, SPECIAL, CONSEQUENTIAL, PUNITIVE OR DIRECT DAMAGES AND/OR LOSSES ARISING OUT OF OR IN CONNECTION WITH THE CREATION, DELIVERY, POSSESSION AND/OR USE OF THIS MANUAL. HOWEVER, NOTHING IN THIS PARAGRAPH IS DEEMED TO EXCLUDE OR RESTRICT ANY LIABILITY WHICH CANNOT BY MANDATORY LAW BE EXCLUDED.

FLOWROXTM IS EITHER REGISTERED TRADEMARK OR TRADEMARK OF VALMET OR ITS SUBSIDIARIES OR AFFILIATES IN THE UNITED STATES AND/OR IN OTHER COUNTRIES. ALL OTHER TRADEMARKS, LOGOS, BRANDS AND MARKS DISPLAYED IN THIS MANUAL ARE PROPERTY OF THE RESPECTIVE OWNERS UNLESS STATED OTHERWISE.

Copyright © 2014-2023 Valmet Corporation. All rights reserved.

Table of Contents

1	EU DECLARATION OF CONFORMITY	4
2	General safety instructions	5
3	Introduction	5
3.1	Applications and purpose of use	5
3.2	General description	6
3.3	Technical data	8
4	Transportation, Storage and Lifting	9
5	Installation	9
5.1	General	9
5.2	Flow direction and support	10
5.3	Dampener installation	10
6	Operation	10
6.1	Commissioning and decommissioning	10
6.2	General maintenance and checks	11
6.3	Changing the hoses	11
6.4	Troubleshooting	15
	Appendix A: Main dimensions of Expulse™ dampener	16

READ THESE INSTRUCTIONS FIRST!

These instructions provide information about safe handling and operation of the product.

If you require additional assistance, please contact the manufacturer or manufacturer's representative.

SAVE THESE INSTRUCTIONS!

Addresses and phone numbers are printed on the back cover.

1 EU DECLARATION OF CONFORMITY



VALMET FLOW CONTROL OY

Marsitie 1

53100 Lappeenranta

Finland

declares herewith under the sole responsibility of the manufacturer that the Expulse pulsation dampener size range DN32-DN100 is in conformity with the European Community's Directive PED 2014/68/EU.

Categorization:

Category I

Properties of fluid:

PED Article 13 Fluid group 2

Conformity assessment procedure:

Module A

Following harmonized standard has been partially applied:

EN 12115:2021

On behalf of Valmet Flow Control Oy

In Lappeenranta, 14th September 2023

A handwritten signature in black ink, appearing to read 'Riku Salojärvi', is positioned above the printed name and title.

Riku Salojärvi

Senior Manager, Operations

2 General safety instructions

The symbols in Table 1 are used in this manual to highlight the parts requiring particular attention.

Hazard severity panels.











	 DANGER! DANGER indicates a hazard with a high level of risk which, if not avoided, will result in death or serious injury.
	 WARNING! WARNING indicates a hazard with a medium level of risk which, if not avoided, could result in death or serious injury.
	 CAUTION! CAUTION indicates a hazard with a low level of risk which, if not avoided, could result in minor or moderate injury.

Table 1. Warning and safety signs.

Symbol	Description
	Risk to personal safety: Neglecting the safety measures can cause serious injury or death.
	Read the operation and maintenance instructions: Read and understand the operation and maintenance instructions before using the product.
	Mandatory action symbol: Obey these instructions to prevent machine malfunctions.
	Forbidden action symbol.

Prevent accidents and ensure the inline pulsation dampener's appropriate operation by complying with the installation, safety, and maintenance instructions in this manual. Installation and maintenance of the dampener must be carried out by persons with appropriate training.

Access to the IOM-manual must be guaranteed at all times at the place of operation of the inline pulsation dampener. It is required to observe the IOM-manual in all work tasks for the dampener.

Use personal protective equipment when performing any checks or maintenance operation for the inline pulsation dampener (goggles, helmet, clothing and gloves). Always follow the factory safety regulations.

In case of any discrepancies between translations, the English version shall prevail.

3 Introduction

3.1 Applications and purpose of use

Flowrox Expulse™ is a flexible inline pulsation dampener, which smoothes noises, restless pipes, pressure peaks and uneven flows. The design is based on double hose structure; damping hose, cover hose and compressed air in between. It may be installed on a pulsating pump from any manufacturer in the market.

The dampener is self-cleaning and does not collect sediment or particles. It is resistant to wearing, corrosion and most chemicals.

Flowrox Expulse™ provides a flexible connection to the pump and tolerates possible misalignments in the pipeline. The dampener can also be easily removed if needed.

Restrictions on use for Expulse™ dampeners

The dampener temperature and pressure range must not be exceeded. The temperature ranges are given in Table 2 for standard hose materials.

The maximum operating pressure for the Expulse™ dampeners is 10 bar (1 MPa). Do not use higher pipeline pressure than rated for the dampener.

The maximum filling air pressure between outer and inner hoses is 6 bar (0,6 MPa)

Table 2. Temperature ranges for Expulse™ dampeners.

Hose material	NR
Min operating temperature (°C)	0
Max operating temperature (°C)	+95

3.2 General description

Principle of operation

The wetted parts of Flowrox Expulse™ dampener are built from stainless steel and NR as a standard structure. The hoses are overlapping creating an air tight space between them. This space is pressurized with oil free compressed air.

The Expulse dampener provides full bore through which the medium can travel. The main components are shown in Figure 1 and Figure 2.

The dampening effect can be adjusted with the air pressure. Normally the needed pressure is 25-40% from the pipeline pressure.

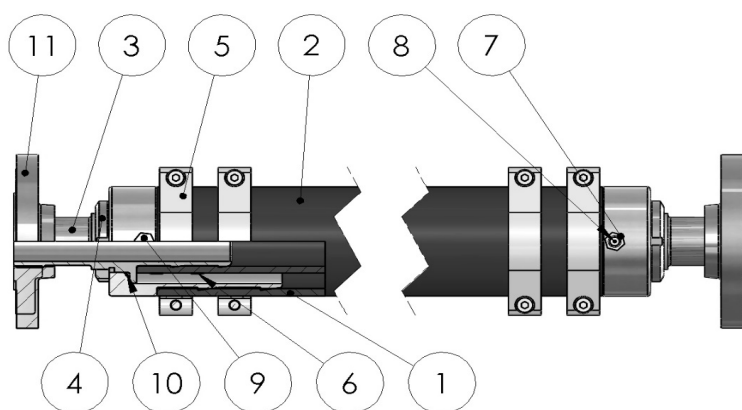

Figure 1. Main components of DN32 to DN65 Flowrox Expulse™ dampeners.

Part	Description	Part	Description
1	Damping hose	7	Valve
2	Cover hose	8	Plug
3	Pulsation hose connector	9	Lock nut
4	Pulsation hose flange	10	O-ring
5	Hose clamp	11	Threaded flange
6	Preformed clamp		

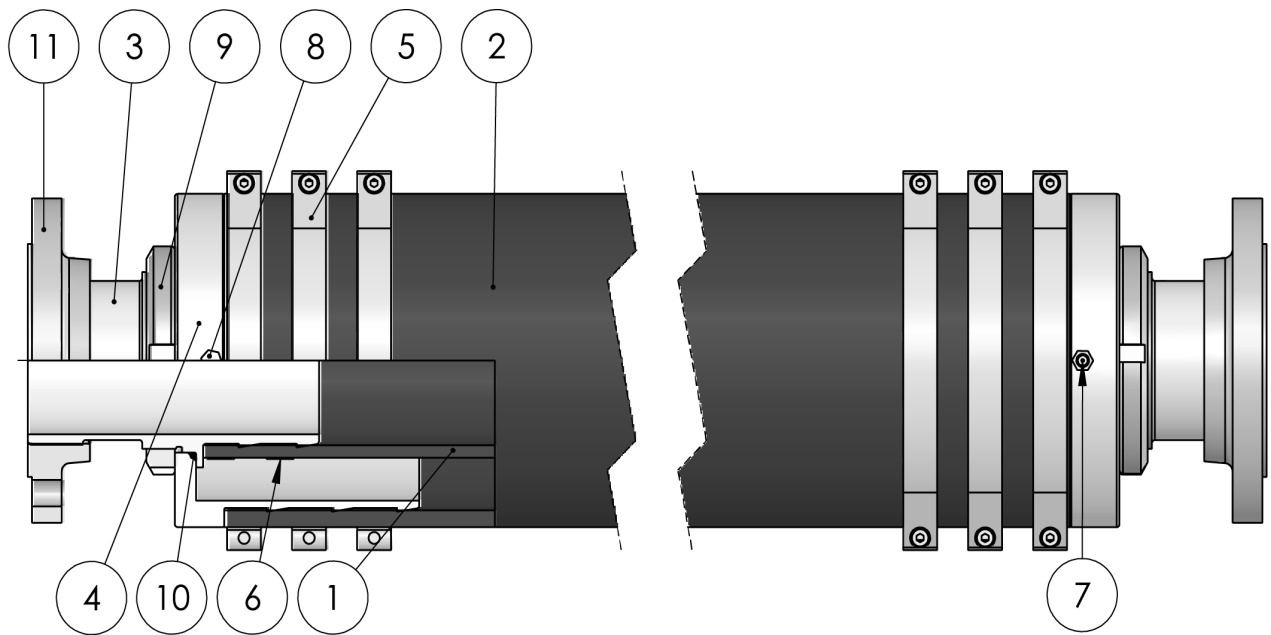

Figure 2. Main components of DN80 and DN100 Flowrox Expulse™ dampener.

Part	Description	Part	Description
1	Damping hose	7	Valve
2	Cover hose	8	Plug
3	Pulsation hose connector	9	Lock nut
4	Pulsation hose flange	10	O-ring
5	Hose clamp	11	Threaded flange
6	Preformed clamp		

3.3 Technical data

Product identification

Flowrox dampener type plate is shown in Figure 3.

Figure 3. Example of type plate.

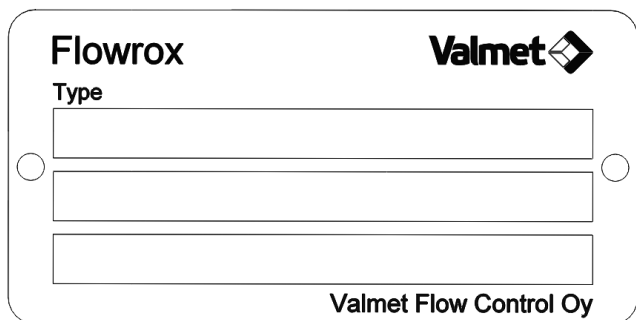

1. Dampener type (see Table 3)
2. Serial number (year, order number, series size, individual serial number)
3. Customer tag number etc.
4. Nominal diameter, pressure class

Table 3. Expulse dampener model key table.

Type	Size (DN)	-	Pressure class (PN)	-	Flanges / Connector	-	Flange/Connector material	-	Wetted parts material
FPD = Flowrox Pulsation Dampener	32 40 50 65 80 100		10 = 10 bar		0 = Threaded connectors 2 = DIN PN10 Flanges 6 = ANSI 150 Flanges		Connector: 0 = FE 2 = AISI316		Hose: NR = Natural Rubber

Example: FPD65-10-0-2-NR

The main dimensions and weight are given in Appendix A: Main dimensions of Expulse™ dampener.

4 Transportation, Storage and Lifting

Check and document any damages in the transport packages or dampeners. Contact the transportation company in case of damage. When new or unused dampeners are sitting idle for long periods, the following procedures should be complied with:

1. Prior to storage, thoroughly drain dampeners of any and all water.
2. Indoor storage is required. For unfavourable environment, cover the equipment with protective tarpaulin that will allow proper air circulation.
3. Protect the equipment from temperature and humidity extremes and exposure to excessive dust, moisture, vibration, sunlight, ozone and solvents.
4. Cover the flange openings.
5. Do not store any objects on top of the rubber hoses.
6. Before operation clean the dampener.

When storing used dampeners, wash them with fresh water and follow the steps above. For storage periods greater than 36 months, please contact Valmet Flow Control as the rubber parts need to be changed before use.

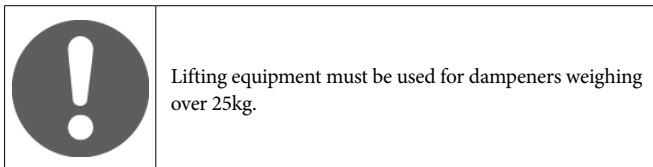

Lift the dampeners securely from the cover hose (part 2). Use soft straps for lifting as shown in Figure 4. Lifting example.

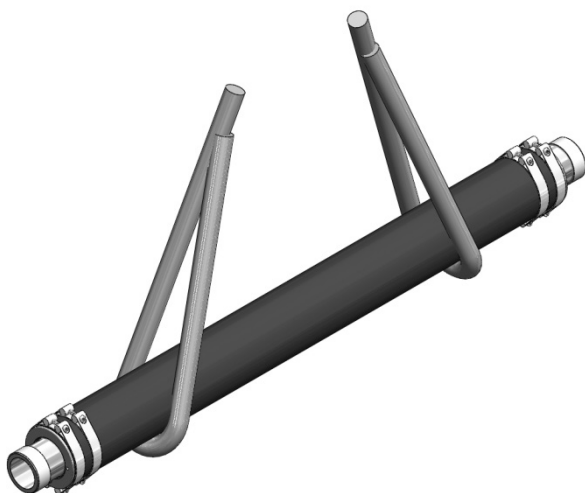
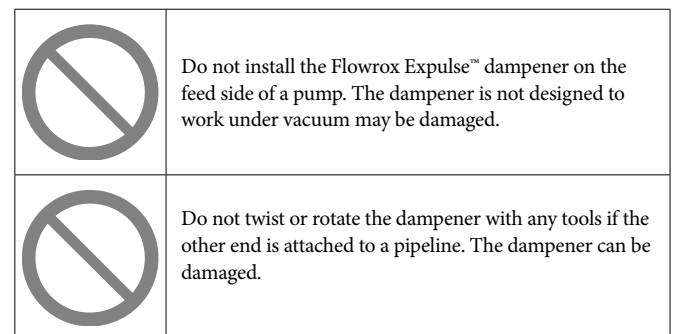
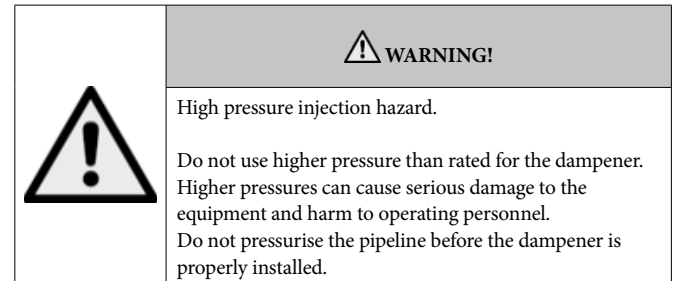

Figure 4. Lifting example.

Do not attach lifting equipment to the bore as it can damage

the dampener. For Expulse™ dampener dimensions and weighs refer to *Appendix A*.

5 Installation



5.1 General

Flowrox Expulse™ inline pulsation dampeners are normally delivered fully assembled and ready for use. Only personnel with appropriate training are allowed to install the dampeners.

If the dampener is delivered disassembled it must be assembled in accordance with the manufacturer's instructions.

Flowrox Expulse™ dampeners include connections with threaded connectors.

Reserve enough space for safe installation and maintenance. See *Appendix A* for Expulse™ dampener dimensions.

5.2 Flow direction and support

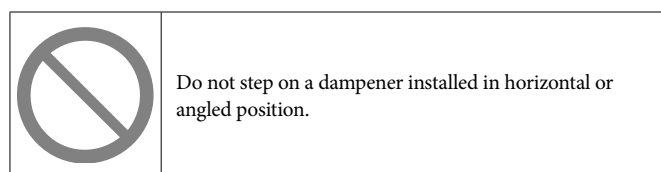

The dampener does not have an intended flow direction; therefore it can be freely installed to the pipeline.

The pipeline needs to be supported before and after the dampener.



Figure 5. Pipeline supports in horizontal installation.

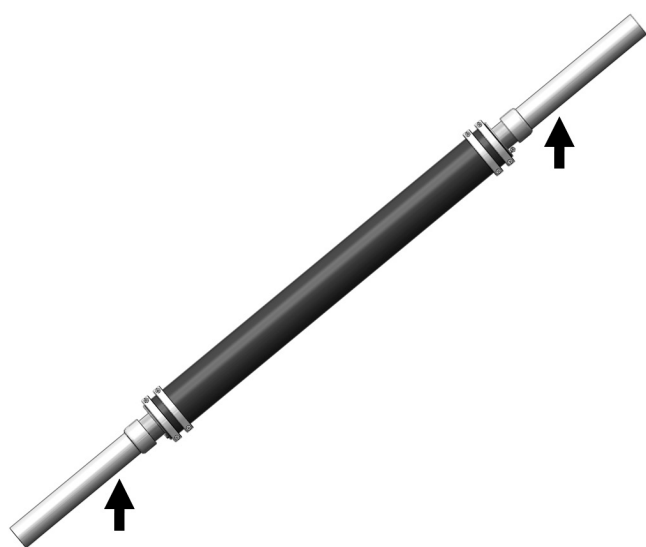

Figure 6. Pipeline supports in angled installation.

5.3 Dampener installation

At least the following must be ensured before Expulse dampener installation:

- The pipeline is isolated from the process and there is no pressure in it.
- The pipeline is empty, clean, and cooled down.
- The pipeline connectors are with proper distance to enable installation of dampener.
- The connector size is correct.
- The pump is locked in OFF position.
- The dampener is not pressurised.

1. Lift the dampener on place with appropriate lifting equipment.
2. Apply pipe tape or hemp on the connector threads.
3. Tighten the connectors between the dampener and pipeline.

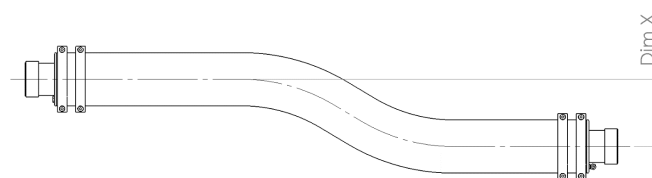

Figure 7. Maximum dimension between the pipeline center axes.

Dim X = 1 x DN size, for example for DN65 dampener dimension X is 65mm (2.56 in).

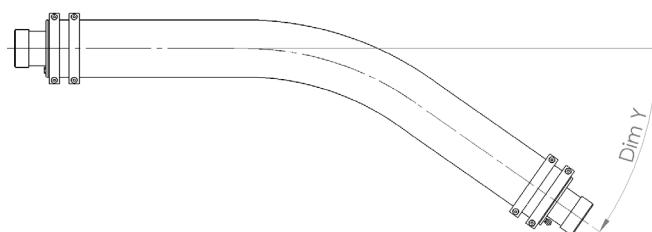

Figure 8. Maximum angle between the pipeline center axes.

Dim Y = 10°



6 Operation

6.1 Commissioning and decommissioning

Before the dampener is operated within the pipeline, ensure that it has been installed in accordance with this manual and applicable safety regulations.

The following must also be ensured:

- Parameters on the type plate are suitable for the process and environment
 - The dampener is used for the purpose specified at the time of sales
1. Turn on the pump and drive it at the design pressure.
 2. Slowly pressurise the dampener through the valve (part 7). Use compressed air with no oil. The maximum filling air pressure is 6 bar (0,6 MPa).
 3. Observe the effects and add more pressure until the wanted dampening effect is reached. Normally the needed pressure is 25-40% from the pipeline pressure.



	The maximum filling air pressure for the dampener is 6 bar (0,6 MPa).
	In case the process pipeline pressure is changed readjust the dampener pressure.

When a dampener is decommissioned, dispose the parts according to the local regulations and the instructions given by the part or device manufacturer.

Collect and dispose dangerous process media, so that people and environment are not endangered. Follow the local regulations.

Servicing and Maintenance

6.2 General maintenance and checks

	 WARNING!
	High pressure injection hazard. Isolate the dampener completely from the process, depressurise and drain it before changing the hoses. Follow the factory safety regulations.

	Do not step on the dampener installed in horizontal or angled position.
-------------------------------------------------------------------------------------	-------------------------------------------------------------------------

Only personnel with appropriate training are allowed to service the dampeners.

Check the condition of the dampener regularly. When the dampener actuates flawlessly, periodic inspection is the only mandatory maintenance task. Do not neglect it as hoses wear over time depending on conditions and process.

Scheduled maintenance

Include the dampeners in your factory maintenance program. Maintenance tasks and service intervals are offered as a guideline in Table 4. Schedules will vary with applications.

Table 4. Maintenance schedule.

Maintenance task	Frequency & advice
Check the dampener pressure.	Every month.
Check the dampener doesn't hit anything and there's no leakage.	Every month.

Spare parts

To ensure correct and quick delivery of spare parts, the order must contain the following information:



- Dampener type number as in type plate (example: FPD65-10-0-2-NR)
- Spare part name and quantity (example: Damping Hose, 1 piece)

You can order the spare parts from Valmet's Flow Control offices, distributors or agents. Contact information is available at <https://contact.neles.com/>

It is recommended to keep 1 set of hoses and clamps as spare parts at your factory warehouse. For part numbers refer to *figures 1 and 2*.

6.3 Changing the hoses

To change the hoses, the dampener needs to be removed from the pipeline. Part numbers refer to *Figures 1 and 2*.

	 WARNING!
	High pressure injection hazard. Do not disconnect a pressurized dampener from the pipeline for any reason.

Removing the hoses

1. Shut down the pump and lock it to OFF position.
2. Depressurise and drain the pipeline according to factory specific orders.
3. Depressurise the dampener with the valve (part 7) on the hose flange.
4. Loosen the flange connections and lift the dampener to a suitable working surface. Use lifting equipment on dampeners weighing over 25kg.

- Cut both the cover (part 2) and damping (part 1) hoses in half.

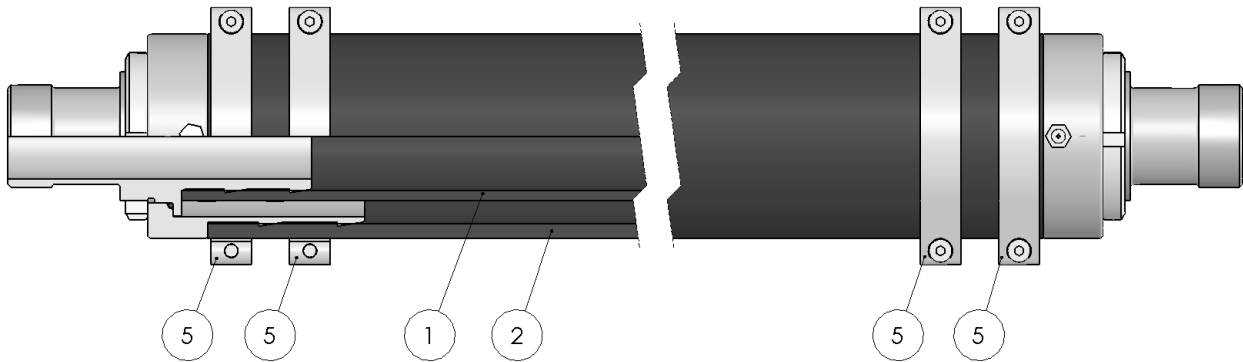

Figure 9. Cutting the hoses.

- Remove the hose clamps (part 5) on the cover hose (part 2).
- Remove the cover hose (part 2).
- Remove the lock nuts (9), pulsation hose flanges (part 4) and o-rings (10).

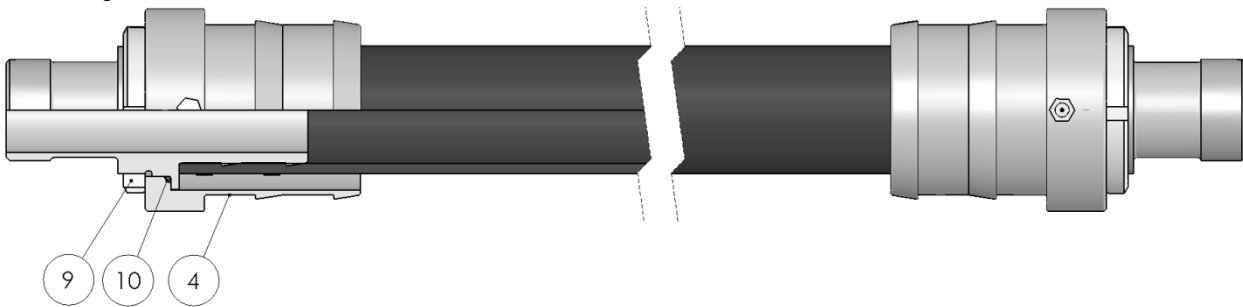

Figure 10. Removing the lock nuts (9), pulsation hose flanges (part 4) and o-rings (10).

- Remove the preformed clamps (part 6) and damping hose (part 1).

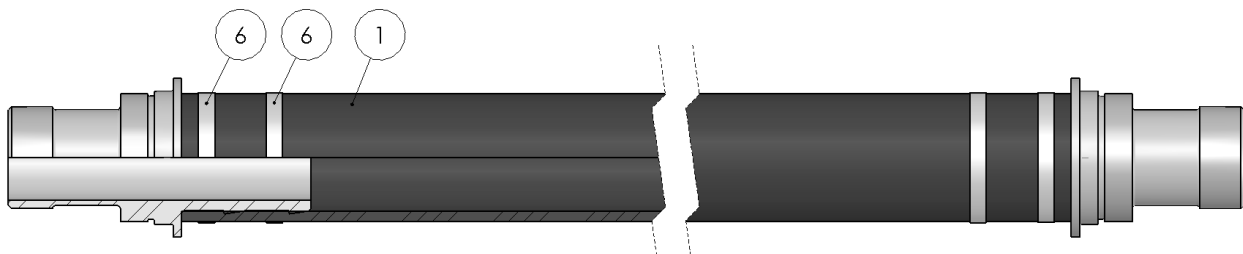

Figure 11. Removing the preformed clamps and damping hose.

- Clean the threads on the pulsation hose connectors (part 3).

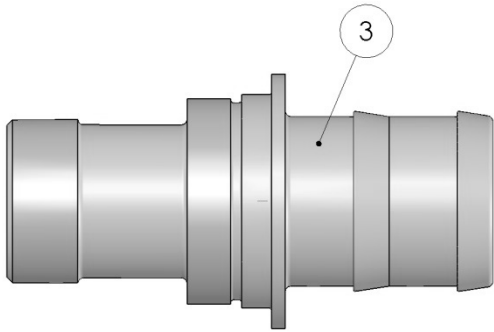

Figure 12. Cleaning the threads.

Installing the hoses

Follow the general tightening torques in Table 5. General tightening torques (bolt class 8.8, lubrication MoS₂), when specific tightening instructions are not given. Part numbers in these assembly instructions refer to *figures 1 and 2*.

Table 5. General tightening torques (bolt class 8.8, lubrication MoS₂).

Size	M6	M8	M10	M12	M16	M20	M24
Tightening torques Nm (ft-lbs)	7 (5)	17 (13)	33 (24)	57 (42)	140 (103)	282 (208)	499 (368)

- Install damping hose (part 1) to the pulsation hose connectors (part 3) and secure them with preformed clamps (part 6).

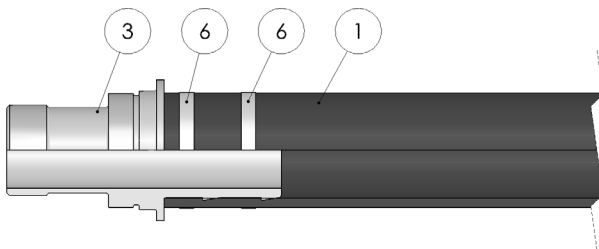

Figure 13. Installing the preformed clamps and the damping hose.

2. Place the o-rings (part 10) on the pulsation hose connectors.

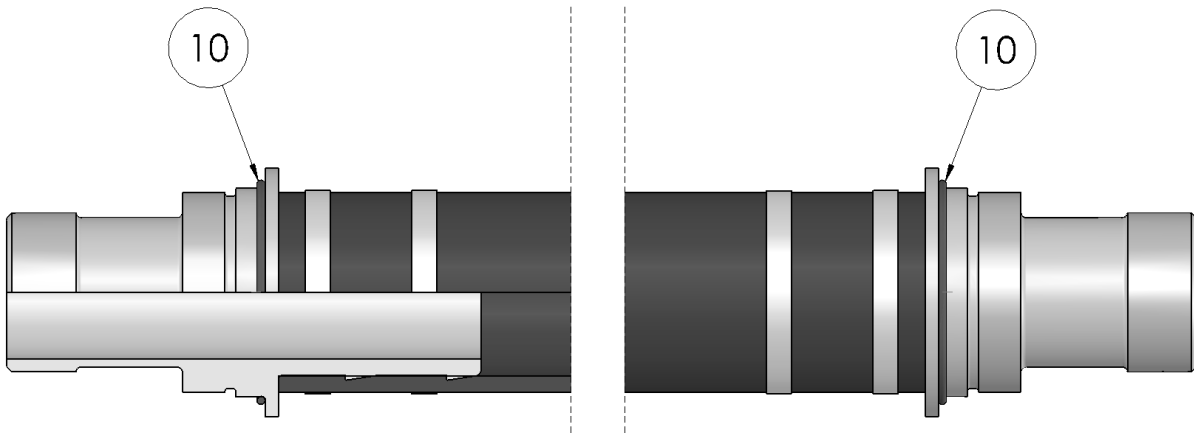

Figure 14. Installing the o-rings.

3. Install one pulsation hose flange (part 4) and plug (part 8) to the other end of the dampener.
4. Install the lock nut (part9) on the pulsation hose flange.

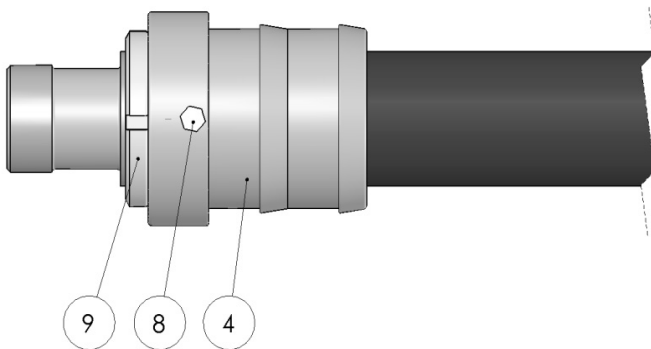

Figure 15. Installing the pulsation hose flange and lock nut.

5. Install the cover hose (part 2).



Figure 16. Installing the cover hose.

6. Install the second pulsation hose flange (part 4) and valve (part 7).
7. Install the lock nut (part 9) on the pulsation hose flange.
8. Install the hose clamps (part 5) to the dampener.



Figure 17. Installing the pulsation hose flange and hose clamps.

6.4 Troubleshooting

Table 6. Troubleshooting.

Problem	Possible reason	Action
Leakage from connection	Connector is loose	Tighten the connector. If needed add pipe tape or hemp fiber to the connection.
Hose lifetime is short	Overpressure in dampener	Adjust the air pressure according to the instructions in commissioning chapter
Dampener does not decrease vibrations / pressure variation	Dampener pressure not correct	Adjust the air pressure according to the instructions in commissioning chapter
	Damaged hose	Check and change damaged parts

Appendix A: Main dimensions of Expulse™ dampener

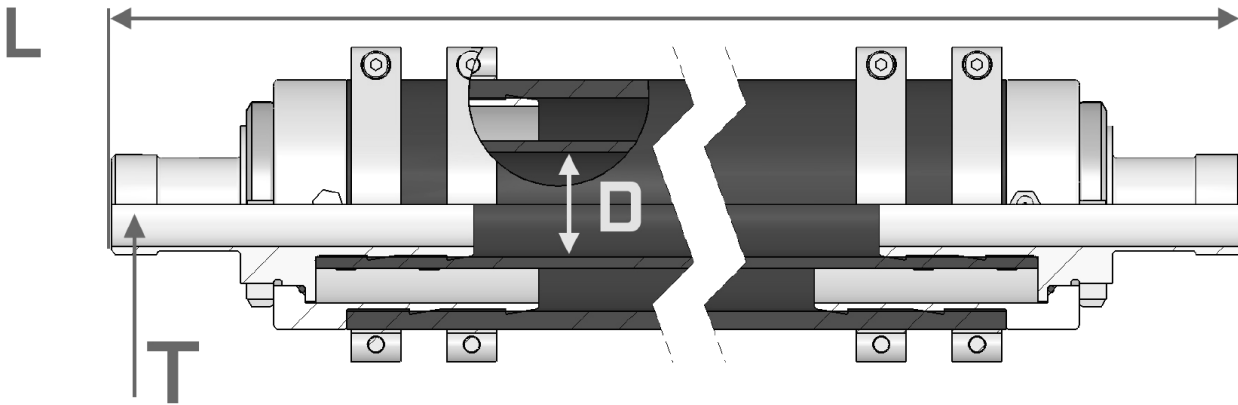

Dampener size (DN)	Length L	Inner diameter D	Threads T	Weight (kg)	Max Pressure (Bar)
32	1100	40	G1-1/4" Threads	7	10
40	1100	50	G1-1/2" Threads	11	10
50	1400	63	G2" Threads	13	10
65	1500	76	G2 1/2" Threads	18	10
80	1500	102	G3" Threads	38	10
100	2000	115	G4" Threads	55	10

Dimensions and weights are for guidance only – detailed drawings are available on request.

All dimensions are in millimetres.

Valmet Flow Control Oy

Marsitie 1, 53600 Lappeenranta, Finland.

Tel. +358 10 417 5000

www.valmet.com/flowcontrol

Subject to change without prior notice.

Neles, Neles Easyflow, Jamesbury, Stonel, Valvcon and Flowrox, and certain other trademarks, are either registered trademarks or trademarks of Valmet Oyj or its subsidiaries in the United States and/or in other countries.

