

Installation, operation, and maintenance instructions for Flowrox™ LPP-D peristaltic hose pumps

Installation, maintenance and operating instructions



These instructions must be read carefully and understood prior to the installation, use, and servicing of this product.

DISCLAIMER

ALL DRAWINGS, SPECIFICATIONS, DATA, SOFTWARE, FIRMWARE, MANUALS, INSTRUCTIONS, DOCUMENTATION OR OTHER WORKS OF AUTHORSHIP FURNISHED BY VALMET ARE COPYRIGHTED PROPERTY OF VALMET OR ITS SUPPLIERS, AND ARE TO BE USED BY CUSTOMER, PURCHASER, SUBCONTRACTOR, SUPPLIER OR OTHER AUTHORIZED PERSONS (“USERS”) ONLY FOR THE PURPOSE OF INSTALLING, OPERATING, MAINTAINING AND REPAIRING THE GOODS AND SERVICES SUPPLIED BY VALMET (“PRODUCTS”). SUCH WORKS AND DATA MAY NOT BE OTHERWISE USED OR REPRODUCED OR DISCLOSED. VALMET OR ITS SUPPLIERS RETAIN ALL RIGHT, TITLE AND INTEREST IN AND TO ITS AND THEIR INVENTIONS, DISCOVERIES, CONCEPTS, IDEAS OR OTHER INTELLECTUAL PROPERTY EMBODIED IN OR RELATED TO ITS PRODUCTS.

ANY AND ALL TRADE SECRETS, SPECIFICATIONS, DRAWINGS, DESIGNS, SOFTWARE, SAMPLES, OTHER TECHNICAL, FINANCIAL, PRODUCT, MARKETING, SALES, PRODUCTION, SUBCONTRACTING, PRICING AND OTHER CONFIDENTIAL AND/OR PROPRIETARY INFORMATION OF A PARTY PERTAINING TO THE PRODUCTS OR OTHERWISE TO THIS CONTRACT, OR TO A PARTY, ITS PRODUCTS, BUSINESSES, OPERATIONS, OR PLANS, SHALL NOT BE DISCLOSED TO ANY UNAUTHORIZED THIRD PARTY BY THE OTHER PARTY. THE RECEIVING PARTY SHALL ENSURE THAT ITS DIRECTORS, OFFICERS, EMPLOYEES AND AGENTS COMPLY WITH THE OBLIGATIONS HEREIN. UNLESS OTHERWISE AGREED TO IN WRITING BY THE PARTIES, THE PARTIES' CONFIDENTIALITY, NON-DISCLOSURE AND NON-USE OBLIGATIONS HEREIN SHALL REMAIN IN FORCE TO THE MAXIMUM TERM PERMITTED BY APPLICABLE LAW.

THIS MANUAL PROVIDES INSTRUCTIONS TO CARRY OUT CERTAIN ACTIVITIES AND IS DESIGNED AND MEANT TO GUIDE AND ASSIST PROFESSIONAL AND PROPERLY TRAINED EXPERTS IN PERFORMING THEIR FUNCTIONS. EVERYONE MUST BECOME FAMILIAR WITH ALL INSTRUCTIONS IN THIS MANUAL BEFORE ANY INSTALLATION, USE, MAINTENANCE, REPAIR OR ANY OTHER ACTIONS OF THE RESPECTIVE GOODS AND/OR SERVICES WHICH THIS MANUAL APPLIES TO. ALL INSTRUCTIONS MUST BE FOLLOWED CAREFULLY. HOWEVER, OBSERVANCE OF ANY PART OF THE INSTRUCTIONS PRESENTED IN THIS MANUAL MAY BE OMITTED IN EVENT WHEN IT IS REQUIRED OR ALLOWED BY LAW. VALMET HAS TAKEN EVERY CARE IN THE PREPARATION OF THE CONTENT OF THIS MANUAL, BUT DOES NOT MAKE ANY REPRESENTATIONS, WARRANTIES OR GUARANTEES OR, EXPRESS OR IMPLIED, AS TO THE ACCURACY OR COMPLETENESS OF THIS MANUAL.

ALL USERS MUST UNDERSTAND AND BE AWARE THAT UPDATES AND AMENDMENTS WILL BE MADE FROM TIME TO TIME TO THIS MANUAL. ALL USERS ARE OBLIGATED TO FIND OUT AND DETERMINE WHETHER THERE HAVE BEEN ANY APPLICABLE UPDATES OR AMENDMENTS TO THIS MANUAL. NEITHER VALMET NOR ANY OF ITS DIRECTORS, OFFICERS, EMPLOYEES, SUBCONTRACTORS, SUB-SUPPLIERS, REPRESENTATIVES OR AGENTS SHALL BE LIABLE IN CONTRACT, TORT OR IN ANY OTHER MANNER WHATSOEVER TO ANY PERSON FOR ANY LOSS, DAMAGE, INJURY, DEATH, LIABILITY, COST OR EXPENSE OF ANY NATURE, INCLUDING WITHOUT LIMITATION INDIRECT, INCIDENTAL, SPECIAL, CONSEQUENTIAL, PUNITIVE OR DIRECT DAMAGES AND/OR LOSSES ARISING OUT OF OR IN CONNECTION WITH THE CREATION, DELIVERY, POSSESSION AND/OR USE OF THIS MANUAL. HOWEVER, NOTHING IN THIS PARAGRAPH IS DEEMED TO EXCLUDE OR RESTRICT ANY LIABILITY WHICH CANNOT BY MANDATORY LAW BE EXCLUDED.

FLOWROX™ IS EITHER REGISTERED TRADEMARK OR TRADEMARK OF VALMET OR ITS SUBSIDIARIES OR AFFILIATES IN THE UNITED STATES AND/OR IN OTHER COUNTRIES. ALL OTHER TRADEMARKS, LOGOS, BRANDS AND MARKS DISPLAYED IN THIS MANUAL ARE PROPERTY OF THE RESPECTIVE OWNERS UNLESS STATED OTHERWISE.

Copyright © 2014-2023 Valmet Corporation. All rights reserved.

Table of Contents

1 EU DECLARATION OF CONFORMITY	4	APPENDIX C: Hose leak detector chart	23
1.1 Mechanical warranty for LPP-D pumps	5	APPENDIX D: Dimensions, LPP-D pumps	24
1.2 Safety instructions for LPP-D pumps	5	APPENDIX E: General safety warnings	25
2 INTRODUCTION	7		
2.1 Applications and purposes of use	7		
2.2 General description	7		
2.3 Electrical equipment	10		
2.4 Technical data	11		
3 TRANSPORTATION, STORAGE AND LIFTING	12		
4 INSTALLATION	12		
4.1 General	12		
4.2 Pump installation	12		
4.3 Electrical connection	13		
4.4 Piping connections	13		
5 PUMP OPERATION	14		
5.1 Commissioning	14		
5.2 Operation	14		
6 SERVICING AND MAINTENANCE	15		
6.1 General maintenance and checks	15		
6.2 Changing the hose	16		
6.3 Maintenance	17		
APPENDIX A: Claim form	21		
APPENDIX B: Tightening torques for the most important bolts	22		

READ THESE INSTRUCTIONS FIRST!

These instructions provide information about safe handling and operation of the product.

If you require additional assistance, please contact the manufacturer or manufacturer's representative.

SAVE THESE INSTRUCTIONS!

Addresses and phone numbers are printed on the back cover.

1 EU DECLARATION OF CONFORMITY

This declaration of conformity is issued under the sole responsibility of the manufacturer:

Valmet Flow Control Oy

Marssitie 1

53600 Lappeenranta

Finland

Tel. +358 (0)10 417 5000

Product model/type: Peristaltic Hose Pump LPP-D and LPP-T

The object of the declaration described above is in conformity with the relevant Union harmonisation legislation:

Machinery Directive 2006/42/EC: Annex II A

ATEX Directive 2014/34/EU: Non-electrical equipment

Follow the pump installation, operating and maintenance instructions in this manual.

On behalf of Valmet Flow Control Oy

In Lappeenranta, 13th May 2022



Riku Salojärvi

Head of Operations

1.1 Mechanical warranty for LPP-D pumps

The warranty is valid for 12 months from the delivery date, excluding the following:

- wear parts, such as gaskets, bearings, rotors and hoses (for requirements concerning hose manufacturing defects, see 'PUMP HOSES')
- pumps that the first buyer has resold without a written agreement with the vendor regarding the remaining portion of the warranty period
- direct or consequential damage caused by structural changes made to the pump or by the use of parts that are not approved by the original manufacturer

The purchaser must file a claim for all compensation related to the hose and/or pump guarantee within 30 days after the fault has been detected. For the claim form, see Appendix.

If the terms indicated in the claim form are not complied with, the purchaser loses his or her right to the guarantee.

The guarantee compensates for new parts if any damaged parts must be replaced. Terms of delivery: packed at the factory, with no other costs covered.

PUMP HOSES:

The hose of the pump is in contact with the pumped product and is exposed to wear, high temperatures, pressure shocks, chemicals and other wearing mechanisms. The pump hose is therefore considered a wearing part that requires periodic replacement.

Flowrox pumps have proved reliable in several demanding applications. However, the operation conditions vary to the extent that we cannot specify an exact service life or guarantee period for the hose. The guarantee applies to only manufacturing defects of the hose.

If there is a manufacturing defect, the customer is entitled to return the defective hoses to the supplier. The supplier shall reimburse the customer for the value of the hoses, excluding the freight charges, packaging costs, and other expenses, upon the following conditions:







the pump has been used only for its intended purpose for all claims regarding a hose fault, the hose in question, along with a description of the operational conditions and method used, has been delivered to Valmet Flow Control Oy for chemical and mechanical analysis





Any reimbursement for a faulty hose shall be made only after the hose's examination.



1.2 Safety instructions for LPP-D pumps

In this manual, the following symbols are used to highlight the parts requiring particular attention:

Hazard severity panels.

	 DANGER!
	DANGER indicates a hazard with a high level of risk which, if not avoided, will result in death or serious injury.
	 WARNING!
	WARNING indicates a hazard with a medium level of risk which, if not avoided, could result in death or serious injury.
	 CAUTION!
	CAUTION indicates a hazard with a low level of risk which, if not avoided, could result in minor or moderate injury.

SYMBOL	DESCRIPTION
	Risk to personal safety: Neglecting the safety measures can cause serious personal injury or death.
	Electrocution hazard: Neglecting the safety measures can cause serious personal injury or death.
	Falling load hazard
	Crushing hazard

SYMBOL	DESCRIPTION
	Read the operation and maintenance instructions: Read and understand the operation and maintenance instructions before using the product.
	Mandatory action symbol: Obey these instructions to prevent machine malfunctions.

	WARNING!
	Crushing hazard. The front cover is part of the pump's safety equipment. Never use the pump without the front cover or with the front cover open.

Prevent accidents and ensure the pump's appropriate operation by complying with the safety instructions indicated in this manual. Installation and maintenance of the pump must be carried out by persons with appropriate training.

The safety aspects have been considered as much as possible in the design of the pump.

Never use the pump with the front cover or inspection glass open. If the glass must be removed for certain maintenance procedures, apply extreme caution. Keep all body parts away from the danger zone.

The pump has been connected to high voltage. The connection box must not be opened when the drive unit is connected. Electrical work must be carried out by professional electricians.

The pump can produce and maintain high pressure. This must be noted when one opens the pipe connections etc. The pipeline can contain high pressure even after the pump has stopped.

Unauthorised personnel are not allowed near the pump when it is in operation. The maintenance and servicing of the pump must be carried out by persons with appropriate training.

Pumps must always be equipped with the safety equipment required by national regulations as appropriate to the place of use. Regardless of national regulations, the pump unit power supply must be equipped with at least the following electrical safety devices:

- emergency switch
- main switch
- motor overload protector
- fuses

The following optional equipment is also considered safety equipment:

- hose leak detector: stops the pump if the hose breaks
- pressure transmitter with display and overpressure limit: stops the pump if the overpressure limit is exceeded

2 INTRODUCTION

2.1 Applications and purposes of use

LPP-D hose pumps are intended for pumping liquids, liquids containing solid matter, sludge, and aggressive liquids.

Normal pumping operations include transfer, dosing, feeding, and drainage pumping. Use for other purposes is forbidden.

Table 1. Suitable industries and applications for LPP-D pumps.

INDUSTRY	APPLICATION
Water and wastewater purification	Chemical dosage and sludge transfer
Mining and metal industry, mineral processing	Sludge and chemicals
Pigments and filling materials	Paper pigments and paints
Chemical process industry	Glue pumping and chemical dosage
Pulp and paper industry	Coatings and solutions
Construction and cement industry	Abrasive raw material sludge
Food industry: breweries, wine factories, soft drink production	Filtering and auxiliary filtering materials, silica filtering

The LPP-D peristaltic hose pump is restarting and gasketless. The gasketless pump is not damaged even if it runs dry for a relatively long time. The only part of the pump that is in contact with the pumped medium is the hose. The hose and rotor are the only parts of the pump that require regular replacement.

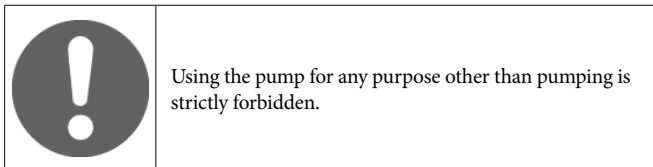

The protection class (IP) of the pump depends on the level of equipment installed. The normal protection class for the motor is IP55.

2.2 General description

Principle of operation

The pump's operation is based on the peristaltic effect: The cylindrical rotor, fitted with a bearing, compresses the hose during the 360-degree working cycle. The rotor is installed on a crankshaft that enables the eccentric movement; as the rotor rotates, it pushes the pumped medium forward in the hose.

After the rotor, the hose returns to its original shape, thus forming a vacuum within. The vacuum then refills with medium from the suction side. The hose compression is adjusted to prevent backflow through the point of compression.

Mechanical structure

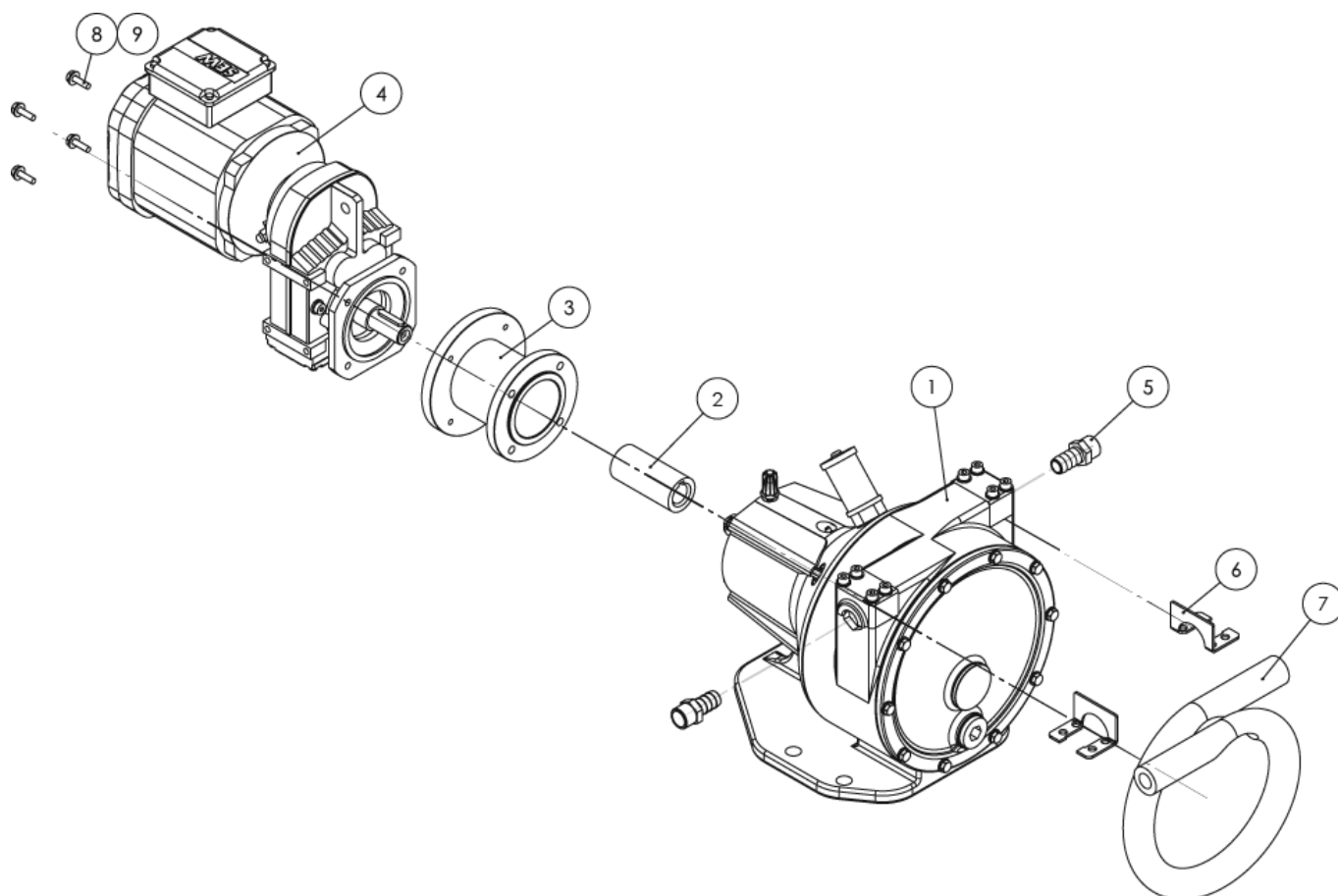

Figure 1. Exploded view of complete LPP-D pump

Item	Description	Qty	Item	Description	Qty
1	Pump head	1	6	Sticker seal	1
2	Coupling	1	7	Hose	2
3	Adapter flange	1	8	Screw	4
4	Gear motor	1	9	Washer	4
5	Hose insert	2			

All exploded parts are modular and order specific. Adapter parts vary depending on the selected gear motor.

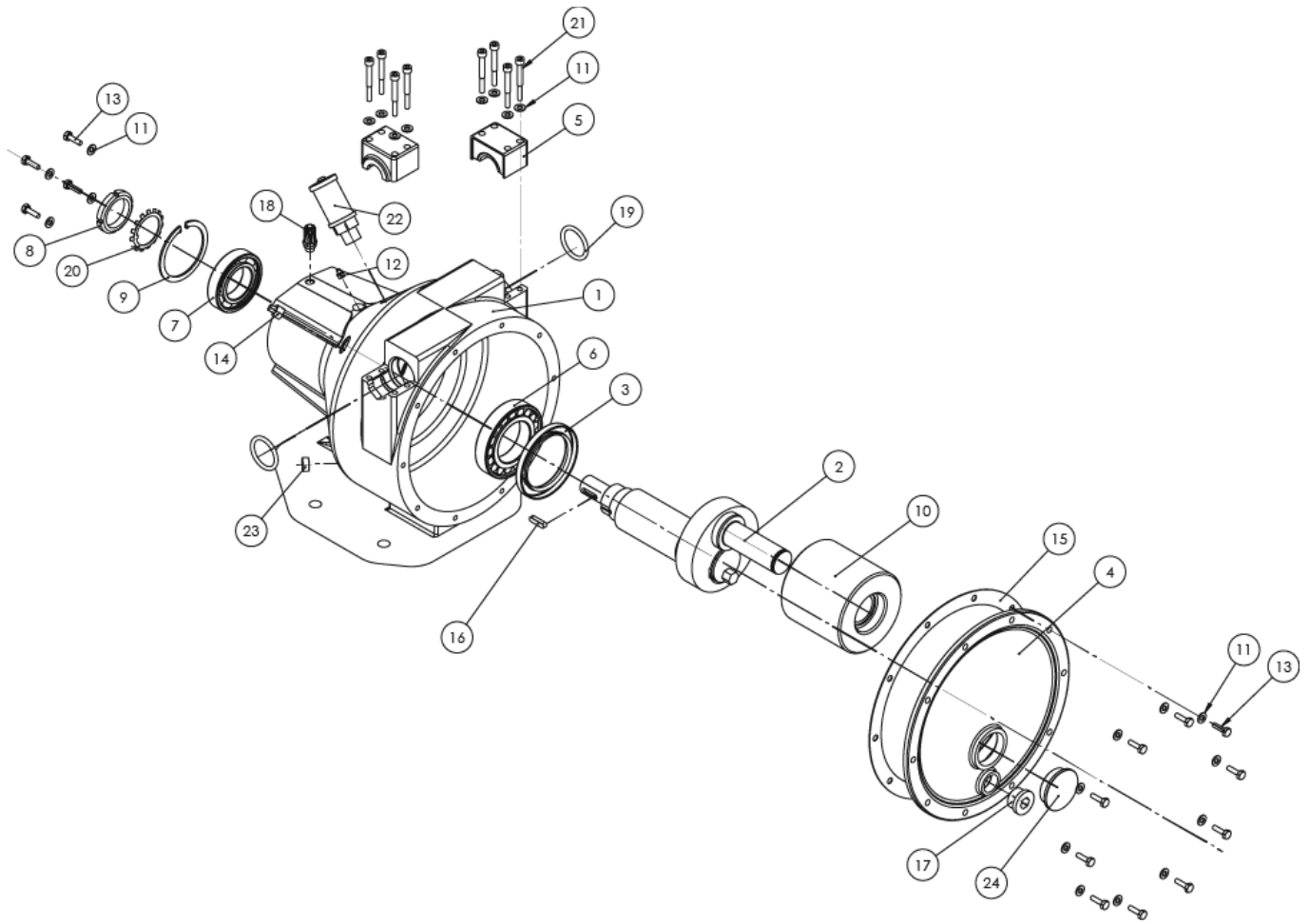

Figure 2. Exploded view of LPP-D pump head

Item	Description	Qty	Item	Description	Qty
1	Body	1	13	Hex screw	14
2	Crankshaft	1	14	Plug	1
3	Radial shaft seal	1	15	Front cover seal	1
4	Front cover	1	16	Parallel key	1
5	Hose bracket	2	17	Plug	1
6	Roller bearing	1	18	Silencer	1
7	Ball bearing	1	19	O-ring	2
8	Shaft nut	1	20	Lock plate	1
9	Retaining ring	1	21	Hex socket screw	8
10	Rotor assembly	1	22	Breather	1
11	Washer	22	23	Hex socket plug	1
12	Grease nipple	1	24	Oil eye	1

The crankshaft has been attached with a bearing to the pole in the middle of the rear wall of the pump housing. The drive unit is connected to the pole with a flange.

The only things changing with the pumped medium and flow parameters are the hose material, nozzles (connections), and drive unit size.

The pump can be equipped with two types of gear motors or gear units. The gear unit alternative is an oblique spur gearwheel or oblique bevel gear. Both are available as gear motors or gear units equipped with an IEC flange for the motor with standard connections.

2.3 Electrical equipment

Recommended electrical equipment:

- hose leak detector

Optional electric control equipment includes the following:

- revolution detector
- frequency inverter (integrated or separate)

The hose leak detector is a two-wire, float-type switch connected with separate attachment parts to the pump rear wall. The detector is of an NC type: if the hose breaks, the fluid level rises inside the housing, and the circuit opens and stops the pump. The pump can be restarted only with the reset function. The resetting method varies according to the pump construction.

- With an integrated inverter, the reversing clutch must be turned to the 0 position and back.
- By pressing the acknowledgement button of the electric cabinet.

The operation speed sensor is an inductive sensor to be installed at the rear wall of the pump. It sends an impulse for each crankshaft rotation detected. The sensor requires an operating voltage of +24 V.

The frequency inverter is used for controlling the pump's rotation speed. The frequency inverter can be delivered integrated with the motor or separately.

The protection class of the integrated inverter is IP 54 (can be delivered with IP66). It can be equipped with a local (potentiometer) or remotely controlled speed adjustment (0...10 V, 0/4...20 mA).

The separate inverter must be installed in a cool and dry location. A signal of 0...10 V can be defined as the setpoint for a separate inverter signal (optional equipment ± 10 V, 0/4...20 mA), with fixed frequencies or bus. The analogue output signal can be scaled to 0...10 V.

	WARNING!
	Electrocution hazard. All electrification connections must be made by professionals only.

2.4 Technical data

Pump parameters

Table 2. Pump parameters.

Pump model	Size categories DN mm (in)	Maximum produc- tion m ³ /h (gpm)	Production per revolu- tion litres (gallons)	Maximum pressure, standard bar (psi)	Maximum pressure, high pressure bar (psi)	Hose diameter and con- nection
LPP-D15 (LPP-D ½)	15 (0.5)	0.6 (2.6)	0.1 (0.026)	7.5 (108)	16 (232)	15 mm, G ½” (½ in, G ½”)
LPP-D20 (LPP-D ¾)	20 (0.75)	1.2 (4.7)	0.18 (0.047)	7.5 (108)	16 (232)	20 mm, G ¾” (¾ in, G ¾”)
LPP-D25 (LPP-D 1)	25 (1)	2 (7.9)	0.3 (0.0793)	7.5 (108)	16 (232)	25 mm, G 1” (1 in, G 1”)

The specifications for optional hoses and equipment available for different pump sizes are given below.

	<p>In addition to drive unit dimensions, the pump output depends on the following factors:</p> <ul style="list-style-type: none"> • the viscosity of the pumped medium • suction height • pipeline length
---	--

Dimensions and weights

The final dimensions and weight of the pump are determined in part by the pump drive unit and optional equipment installed. The main pump dimensions are shown in the Appendix: General arrangement drawings.

3 TRANSPORTATION, STORAGE AND LIFTING

The LPP-D pump is delivered in a transport container. Use the original container for storing and transporting the pump until the final installation. Store the pump in a dry, cool place protected from sunlight. Before unpacking the pump from the transport box, ensure that the pump foundation is finished and of the correct size and materials.

If the pump unit is stored for a long time, carry out the following procedures:

- Rinse the pump clean of the medium.
- Remove the hose from the pump, or release the hose compression to prevent fatigue of the hose during storage.
- Clean the pump housing.
- Store the pump in a dry, cool place +5 - +20 °C (+41 - +68 °F) protected from sunlight.

	WARNING!
	Falling load hazard. Lift the pump only with approved lifting equipment with a sufficient carrying capacity. Obey the lifting equipment instruction manuals.

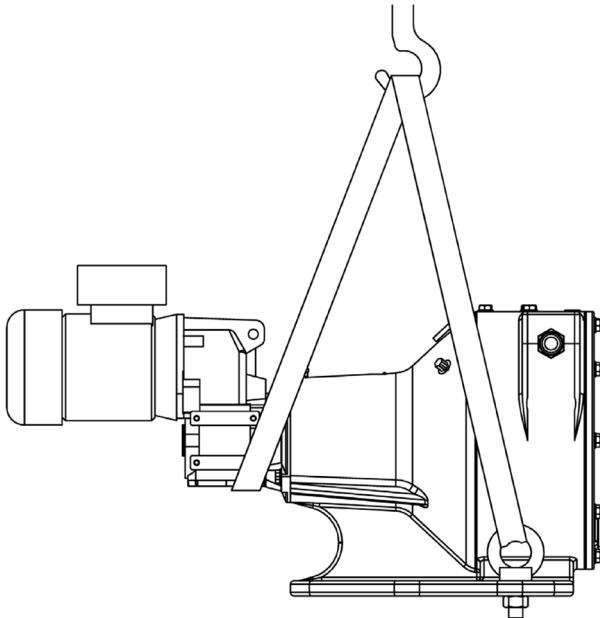



Figure 3. Hoisting the pump

Lifting ropes must not be attached to the lifting eye of the gearbox or the motor.

4 INSTALLATION

4.1 General

	LPP-D pumps are intended for use in industrial applications and facilities. They must be installed indoors and protected from direct sunlight, rain, and cold.
---	--

Only professional personnel with appropriate training are allowed to install an LPP-D pump. All installation and servicing tools and values are metric.

The following tools are required to install the pump:

- spanner set
- Allen wrench set
- torque wrench (up to 300 Nm)
- screwdrivers (for electrical connections)

The pump must be installed on the pedestal that is part of the pump frame.

The LPP-D pumps are normally delivered assembled and ready for use (except if the pump is delivered with an IEC flange gear unit without the engine) and ready for use. The hose and lubricant have been installed in the pump.

4.2 Pump installation

The pump is delivered in a transport package that protects the pump during transport. For more information, see Chapter 3: 'Transportation, storage and lifting.'

Table 3. Required distances around the pump (for servicing and cooling).

Model	Front m (ft)	Right m (ft)	Left m (ft)	Behind m (ft)
LPP-D15, 20, and 25 (LPP-D ½, ¾, and 1)	1 (3)	0.5 (1.6)	0.5 (1.6)	0.15 (0.5)

Install the pump on a suitable foundation with foundation bolts or threads for them. See the basic pump dimensions in section 2.4.2, 'Dimensions and weights.' The pump must be bolted to the foundation with foundation bolts that go through the pump stand, Using other attachments is not allowed. Make sure that the foundation can take the pump weight and any vibration caused during operation.



	The only installation position allowed is with the stand downwards.
---	---

Table 4. Bolts for the pump foundation and their tightening torques.

Model	Bolt	Tightening torque (Nm)
LPP-D15, 20, and 25 (LPP-D ½, ¾, and 1)	M16 x 70	210

	Always tighten the bolts in a crosswise sequence and double check to make sure correct torque is reached.
---	---

When the foundation is ready for assembly:



- Lift the pump as instructed in Chapter 3 and lay it on top of the foundation.
- Tighten the foundation bolts with the torque wrench in accordance with the torques indicated in Table 4 ('Bolts for the pump foundation and their tightening torques').
- Remove the transport supports, if any.

	If the pump is installed in dirty surroundings where its motor is susceptible to fluid splashes, or dust, the motor must be equipped with protection. An unclean motor can overheat and become damaged.
---	---

	If the pump to be installed is equipped with a gear unit with an IEC flange, the motor can be installed in the gear unit after the pump has been bolted to the foundation. The motor must be installed in accordance with the manufacturer's instructions.
---	--

4.3 Electrical connection

The motor connection must be performed in accordance with the manufacturer's instructions. The instructions are delivered with the motor unit.

	 WARNING!
	Electrocution hazard. Before installation or maintenance, ensure that the supply voltage has been turned off. All electrification connections must be made by professionals only.

	Electrocution hazard. Always ensure that the operating voltage conforms with pump and control unit requirements.
--	--

4.4 Piping connections

The pump's flow direction is both ways.

	Especially in pumping of heavy sludge, the minimum flow velocity must be taken into consideration, to prevent the sedimentation of the medium.
--	--

Connected piping should meet the following requirements:

- To minimise pressure loss, the nominal size of the piping should be at least one size larger than the nominal size of the pump.
- The pump should be connected to the piping with flexible, pressure-proof hoses to facilitate maintenance work and to dampen the pressure shocks (pulsation) generated by the pump. The amount of pulsation (pressure change) depends on the following factors: the counter pressure of the piping, the capacity of the piping, the flow velocity, equipment installed in the piping, and the rotation speed of the pump.
- The strength of the pipeline supports should be taken into consideration, as the vibration in the piping may cause strain in the pump housing.
- If the pressure shocks of the pump disturb the pumping process, the pulsation can be dampened with special pulsation dampers installed in the pipeline.
- If there are closing valves on the delivery side of the pump, a pressure relief valve that prevents overpressure must be installed between the valve and the pump.

The intake and pressure connections of the pump are threaded. See the following table for connection sizes.

Table 5. Intake and pressure connection sizes.

Model	Connection nozzles
LPP-D15 (LPP-D ½)	G ½" (G ½")
LPP-D20 (LPP-D ¾)	G ¾" (G ¾")
LPP-D25 (LPP-D 1)	G 1" (G 1")

5 PUMP OPERATION

The LPP-D pumps are normally delivered with pre-installed hose and lubricant. Also the drive unit (gearbox and motor) is installed prior to the delivery of the pump. In this case, the pump is ready to be used with the nominal parameters indicated on the pump's type plate. If the pump is delivered without the gear motor (pump head delivery), the gear motor must be installed in accordance with the manufacturer's instructions.

5.1 Commissioning

Before starting the pump, ensure that it has been installed in accordance with the instructions in this manual and applicable safety regulations.

At least the following must be ensured:

- The pump is used only for the purpose specified at the time of sale.
- The hose installed is compatible with the pumped medium.
- The parameters on the type plate are suitable for the process values required of the pump and that the piping the pump is connected to has sufficient ability to withstand pressure.
- The required pressure relief valves have been connected and work correctly.
- Electrical work has been carried out by an authorised electrician.
- Starting the pump does not put personnel or equipment in danger.
- The pump is correctly connected to the piping and all connections are pressure-proof.
- The valves of all suction and pressure lines connected to the pump are open.
- The pump settings are correct.
- The amount of hose lubricant is sufficient.
- If the pump is equipped with a frequency inverter, the minimum frequency set is sufficient to ensure the cooling of the pump in all conditions. If the required minimum frequency is below 20 Hz, the pump must always be equipped with an additional cooling fan.

5.2 Operation

The maximum operation speed for all LPP-D pumps is 110 rotations per minute. If a greater speed is needed, contact our local representative.

After starting, the pump starts rotating at its nominal speed (unless it is equipped with a frequency inverter). The nominal speed produces a nominal volume flow.

If the pump is equipped with a frequency inverter, the rotation speed of the pump depends on the value set for the frequency inverter. If the pump is controlled with a frequency inverter using slow rotation speeds, ensure that the pump motor does not overheat.

	Never close the pump valves on the delivery side of the pump, as this may cause overpressure and damage the pipeline or the pump.
---	---

If the solid matter content of the pumped medium is high, the pipe lines must be flushed when the pump is stopped. This prevents the formation of blockages in the piping caused by sedimentation of the medium.

	A hose leak detector can be delivered with the pump. The product must be connected to the control system in order to guarantee correct operation.
--	---

The need to replace the hose or rotor can be monitored during use of the pump by checking the volume flow of the pump and the pump velocity. If the volume flow per rotation is lower than the nominal production per rotation, the hose or rotor must be replaced.

6 SERVICING AND MAINTENANCE

6.1 General maintenance and checks

The process functions of peristaltic hose pumps are often critical. In order to guarantee problem-free and reliable operation, the pump must be monitored, and a basic check must be performed daily.

The hose used for transferring the pumped medium is the only part of the pump that requires regular replacement. Checking the condition of the hose is therefore the most important maintenance procedure for the pump.

In changing the hose, it is recommended to also replace the gasket rings and sticker seals used for sealing the hose and frame inlets and to use the correct amount of LPP-D lubricant.

Observation during use

The condition of the pump hose must be checked regularly. Checking is done by visual estimation of the condition of the hose and by monitoring the flow meter parameters.

Observation of the pump condition on the basis of flow parameters is based on the volume flow produced by the pump and on the rotation speed of the pump. The volume flow l/min (g/min) produced by the pump is divided by the rotation speed (rpm) of the pump. The resulting volume flow per revolution figure is compared with the equivalent figure of a new hose, or with the figure given in the pump's technical specifications.

The best result is achieved when the comparison is performed using the figure for a new hose. If the production per revolution is considerably less than the comparison figure (more than 5%) the hose must be changed. The volume flow produced by the pump depends on the properties of the pumped medium (viscosity, density, etc.), the suction height, etc. Reduced production per rotation indicates backflow is occurring via the compression point.

The condition of the gear unit and the bearing gaskets can be checked visually for oil or grease leaks. If any leaks are detected, the gaskets (and bearings, if necessary) must be replaced.

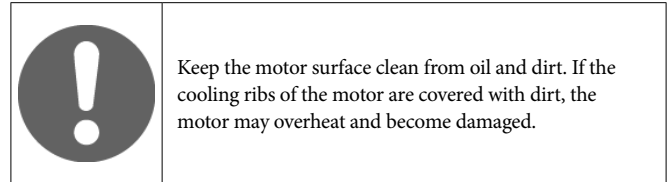
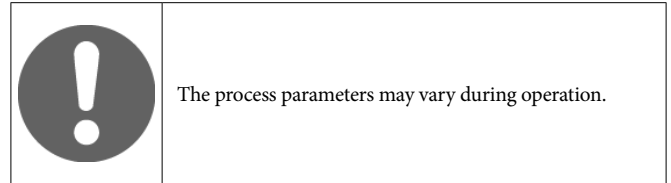

Spare parts

To ensure correct and quick delivery of spare parts, the order must contain at least the following information found on the type plate of the pump:

- pump serial number
- pump type
- nominal production and pressure of the pump
- manufacturing year of the pump

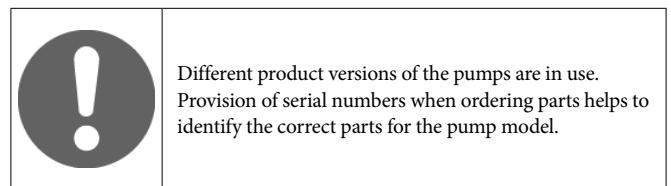



The pump parts, with corresponding number or code, can be found in the drawings at the end of this manual.

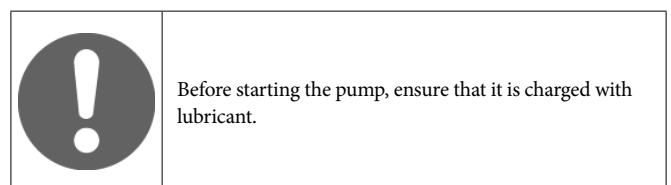

Lubrication

Lubricating the hose

The LPP-D pump hose has been lubricated with friction-reducing LPP hose lubricant. The operating temperature range of the lubricant is $-20\text{ }^{\circ}\text{C} \dots +100\text{ }^{\circ}\text{C}$ ($-4\text{ }^{\circ}\text{F} \dots +212\text{ }^{\circ}\text{F}$), and it must be added to the pump housing as the hose is installed or replaced. The correct lubricant amount is 0.4 litres (0.1 gallons). High pressure pump (with support rotors) 1.0 litres (0.26 gallons). This applies to all LPP-D pump models.



	 CAUTION!
	<p>Always ensure that the lubricant is compatible with the pumped medium. Even if the LPP hose lubricant is extremely stable, it may react with oxidising substances, such as certain acids.</p> <p>In unclear situations, always contact your local LPP representative and ask for further information.</p>

	 CAUTION!
	<p>Liquid inside the pump may be harmful to personnel and the environment. Use appropriate protective equipment. Obey local waste treatment regulations.</p>
	<p>Do not allow unauthorised persons near the pump during maintenance work.</p>

Lubricating the bearings

The pump unit bearings and frame bearings are greased for three months of normal operating conditions. Add 20g (0.71 oz) more grease to the main bearings after every three months of operation.

Add grease to the rotor bearings after each hose replacement.

The suitable grease type for the bearings is SKF LGHP2 or equivalent.

	<p>If the pump is used in abnormal conditions (high temperature or high relative air humidity), the grease may not last as long. In such cases, more frequent greasing is recommended to avoid bearing damage.</p>
---	--

	<p>Do not add too much grease to the bearings. It might force the seals out of their positions. Needed amount of grease depends about the hose replacement interval and pump utilization degree.</p>
--	--

Lubricating the gearbox

The gearbox must be lubricated in accordance with the manufacturer's instructions (delivered with the unit).

6.2 Changing the hose

Preparations

Before starting maintenance work, clean the pump and the area around the pump. Ensure that no impurities can enter the pump.

Empty the pipelines from both sides of the pump, and close the inlet and outlet valves.

Removing the hose

1. Cut off the power supply to the pump.
2. Lock the maintenance switch so that the pump cannot be switched on during the maintenance work. When replacing the hose, rotate the pump with the motor's fan blades.
3. Empty the pump housing from the LPP-lubricant by opening the drain valve or front cover. Cover yourself, since the medium may splash from inside the pump.
4. Remove the front cover by opening its bolts.
5. Remove the motor ventilation cage.
6. Turn the rotor to its lower position by using the motor ventilation blades.
7. Open the hose clamps on both sides of the pump.
8. Remove the threaded connections from the ends of the hose.
9. Pull the hose ends inside through the pump openings.
10. Remove the O-ring.
11. Pull the hose out from the housing.
12. Clean the following parts carefully before installing the new hose:
 - pump housing
 - hose leak detector
 - breather
 - rotor
 - (support rotors if there are)

	<p>In the event of hose puncture, the hose leak detector and breather must be cleaned, to ensure correct operation of the LPP-D pump.</p>
---	---

	<p>Remove foreign particles from inside the pump housing. They may break the pump or significantly shorten the life of the hose.</p>
---	--

Installing the hose

1. Lubricate the pump openings with LPP hose lubricant in order to facilitate the installation, and push the hose ends to the openings from inside the housing.
2. Install new O-rings at the pump openings and sticker seal to the hose clamps.
3. Push the hose ends through the holes so that the hose end touches the edge of the groove in front of the opening. (A)

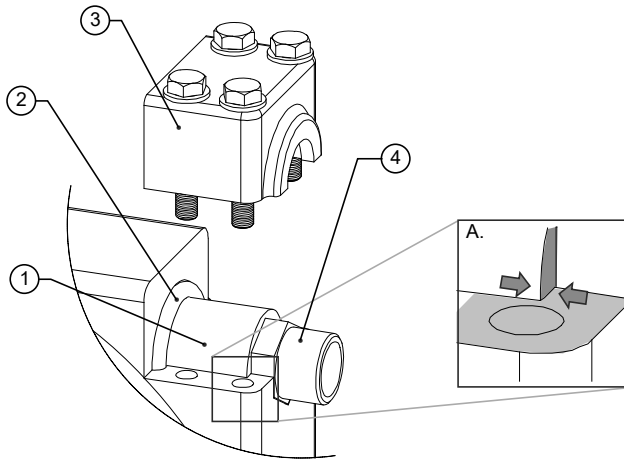

Figure 4. Hose connections

4. Push the end connection into the hose. Ensure that the hose is firmly in place.
5. Attach the hose clamp and its bolts in place on both sides.
6. Push the lower part of the hose to the pump housing between the rotor and the housing. You can facilitate the installation by rotating the rotor by means of the ventilation blades.
7. Check that the nozzles are in their correct positions in the corresponding grooves.
8. Close the front cover, and add hose lubricant to the pump housing through the plug on top. The correct lubricant amount is 0.4 litres (0.1 gallons) or for high pressure pumps with support rotors 1.0 litres (0.26 gallons).
9. Close the plug.

6.3 Maintenance

Replacing the rotor

Before starting the maintenance, ensure that you have all necessary spare parts.

Disassembling the rotor

1. Lock the maintenance switch so that the pump cannot be switched on during the maintenance work. When replacing the hose, rotate the pump with the motor's fan blades.
2. Remove the front cover by opening its bolts.
3. Remove the hose in accordance with the instructions in section 6.2.2, 'Removing the hose'.
4. Remove the locking ring and the support ring.
5. Pull the rotor out from the crankshaft.

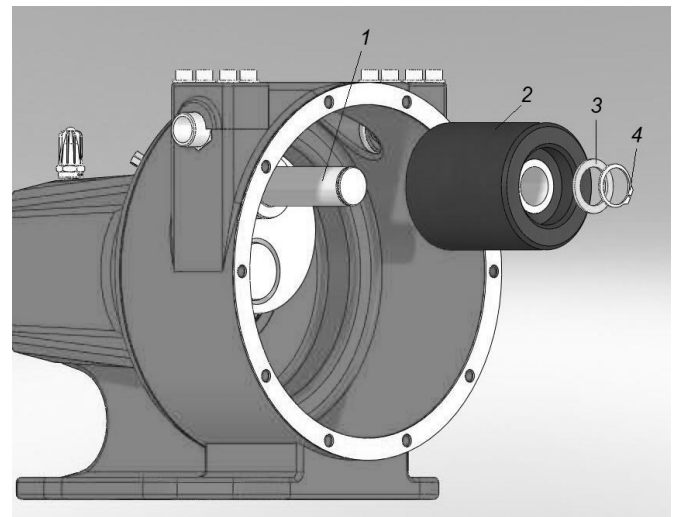

Figure 5. Rotor

Item	Description	Item	Description
1	Crankshaft	3	Support ring
2	Rotor	4	Locking ring

Disassembling the rotor from high pressure pump

1. Lock the maintenance switch so that the pump cannot be switched on during the maintenance work. When replacing the hose, rotate the pump with the motor's fan blades.
2. Remove the front cover by opening its bolts.
3. Remove the hose. Refer to the section 6.2.2, 'Removing the hose'.

4. Remove the gasket plug in the middle of the rotor.
5. Remove the locking ring and the support ring also from the support rotors.
6. Pull the rotor assembly out from the crankshaft, also pull support rotors.
7. Remove the gasket and the bearings from the rotor.

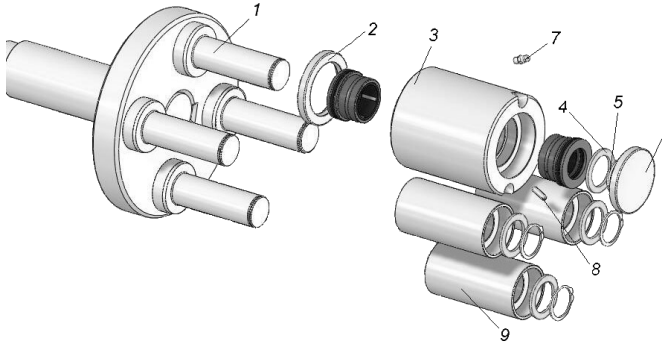

Figure 6. Rotor assembly

Item	Description	Item	Description
1	Crankshaft	6	Gasket plug
2	Gasket	7	Grease nipple
3	Rotor	8	Air plug
4	Support ring	9	Support rotor
5	Locking ring		

Assembling the rotor

8. Add grease on the crankshaft pin.
9. Attach the rotor to the crankshaft.
10. Install the support ring and locking ring for the rotor.
11. Reinstall the hose as instructed under 'Changing the hose'.
12. Close the front cover by tightening the bolts.

Assembling the rotor for high pressure and ATEX pumps

1. Add grease on the crankshaft pins.
2. Install the bearings to the rotor, and reinstall the gasket.
3. Attach the rotor to the crankshaft.
4. Attach the support rotors to the crankshaft pins (high pressure pumps).
5. Install the support rings and locking rings to the rotor and support rotors.
6. Check that there is no axial play on the rotor. See the figure below.

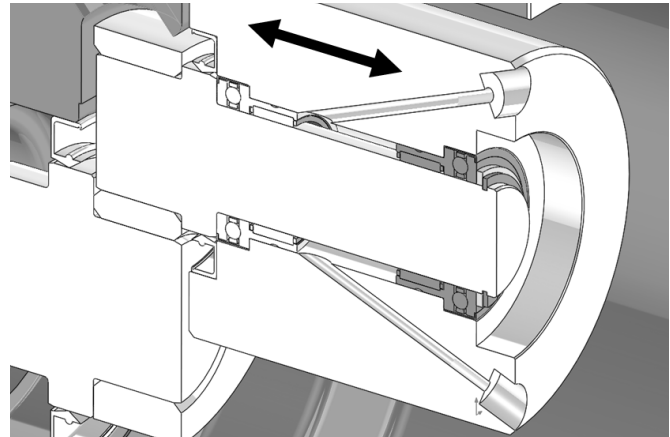

Figure 7. Rotor assembly on ATEX pump

7. Add support rings between the bearing and locking ring on the rotor until there is no play on the rotor.
8. Reinstall the gasket plug in the middle of the rotor.
9. Open the air plug and lubricate the rotor bearings with grease.
10. Close the air plug.
11. Reinstall the hose as instructed under 'Changing the hose'.
12. Close the front cover by tightening the bolts.

Do not use hammering tools at any point in the assembly. Pre-grease the bearings before installation.

Gearbox assembly

Detaching the gearbox

1. Isolate the power source, and remove the wires from the motor.
2. Support the gear unit and the motor with a hoist.
3. Remove the gearbox flange bolts.
4. Pull the gearbox/motor unit off the pump, and place it on a worktable.

The gear unit is attached to the LPP-D pump in the reverse order.

Add the amount of grease that was removed during the operation and replace the paper seal.

Crankshaft and main bearing assembly

First, detach the rotor and gear unit as described above.

1. Make sure that the power supply has been isolated and the wires disconnected.
2. Straighten the bent part of the lock washer so that it is removed from the locking nut groove, and remove both parts from the crankshaft.
3. Remove the crankshaft from the pump housing by pushing it from the gearbox side, and put it on the table.
4. Remove the locking ring from the body frame pole and pull out the rear bearing.
5. Pull out the shaft seal and front bearing.
6. Clean all parts and the pump frame. Ensure in particular that no impurities can enter the pump during the maintenance procedures.
7. Lubricate the bearings (see 'Lubrication'). Check the removed parts for wear. Replace the worn parts with new, original parts if necessary.

5. Attach the rear bearing as a unit to the frame, and install the bearing's locking ring in its place.
6. Pull the crankshaft to the pump unit from the front side.
7. Install the lock washer on the shaft and tighten the lock nut. Lock the nut with the lock washer and fill the bearing housing with grease. See the appropriate locking nut tightening torque in Appendix, 'Tightening torques for the most important bolts'.

Assemble the rotor and the gear unit. See the chapter covering rotor and gear unit maintenance.

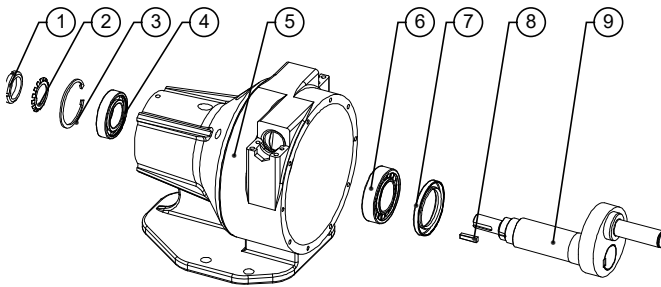
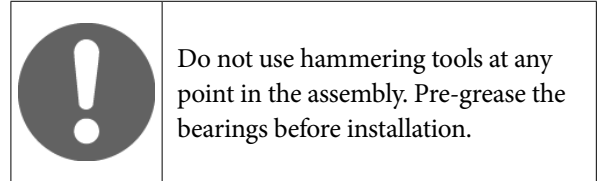

Figure 8. Crankshaft and main bearing assembly

Item	Description	Item	Description
1	Lock nut	6	Front bearing (ball bearing)
2	Lock washer	7	Shaft seal
3	Locking ring	8	Wedge
4	Rear bearing (ball bearing)	9	Crankshaft
5	Pump frame		

Assembling the crankshaft

1. The crankshaft assembly proceeds in reverse order to the disassembly process.
2. Ensure that the bearings have been lubricated prior to the installation. Remove the inner ring from the front bearing, and install it on the crankshaft by heating the inner ring to 110 °C (230 °F).
3. Install the front bearing without inner ring on the frame.
4. Press the shaft seal to the frame on top of the first bearing.

Troubleshooting

Table 6. Troubleshooting.

PROBLEM	POSSIBLE REASON	ACTION
The pump won't start.	The power has been turned off. No power supply has been connected. Problem with the power supply. Safety switches activated.	Turn the power on. Connect the power supply (authorised electrician only). Check the power supply (authorised personnel only: fix the supply voltage and frequency). Acknowledge the safety equipment.
The pump is running, no production.	Intake valve closed. Obstruction in the intake line.	Open the suction valve. Clean the intake line.
The pump is running with less production than expected.	The viscosity / solid density of the pumped medium is too high. The suction line is partly blocked. The suction height is too great.	Compare the pump size parameters and medium properties. Clean the intake line. Check the pumping arrangement.
The service life of the hose is short.	Not enough lubricant, or the wrong lubricant. There are large particles in the pumped medium that disturb the hose operation. Too much compression.	Add lubricant or change it. Prevent large particles from entering the pump. Change smaller rotor.
The pump does not restart after stopping.	The pressure in the pressure line is too high. The pressure line is blocked. The pump is blocked.	Reduce the pressure-side pressure by operating the pump backwards. Flush the pressure pipe line. Empty/replace the pump hose.
The pump housing is filled with fluid.	Hose puncture.	Clean the pump housing and change the hose. Acknowledge the safety equipment.

APPENDIX A: Claim form

The purchaser must file a claim for all compensation related to the hose and pump guarantee within 30 days after the fault has been detected.

The following information must be included. Fill in the form using block letters, or provide the manufacturer with the same information in another manner. In any instance, the claim must be made in writing.

PUMP SERIAL NUMBER:	
DATE WHEN THE FAULT WAS DETECTED (dd.mm.yyyy):	
OPERATING CONDITIONS IN WHICH THE FAULT WAS DETECTED:	
DESCRIPTION OF THE FLOWING MEDIUM:	
AN EXACT DESCRIPTION OF THE FAULT:	

If all of the above information is not sent to the manufacturer in writing, the purchaser loses the right of guarantee.

APPENDIX B: Tightening torques for the most important bolts

1. Tightening torque for the hose clamp bolts:

LPP-D15/20 (LPP-D $\frac{1}{2}$, $\frac{3}{4}$):	25 Nm
LPP-D25 (LPP-D 1):	25 Nm

2. Tightening torque for the front cover bolts:

LPP-D15/20 (LPP-D $\frac{1}{2}$, $\frac{3}{4}$):	1 Nm
LPP-D25 (LPP-D 1):	1 Nm

3. Tightening torque for the gear motor installation bolts:

LPP-D15/20 (LPP-D $\frac{1}{2}$, $\frac{3}{4}$):	10 Nm
LPP-D25 (LPP-D 1):	20 Nm

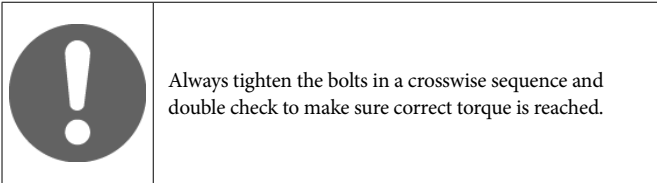

APPENDIX C: Hose leak detector chart

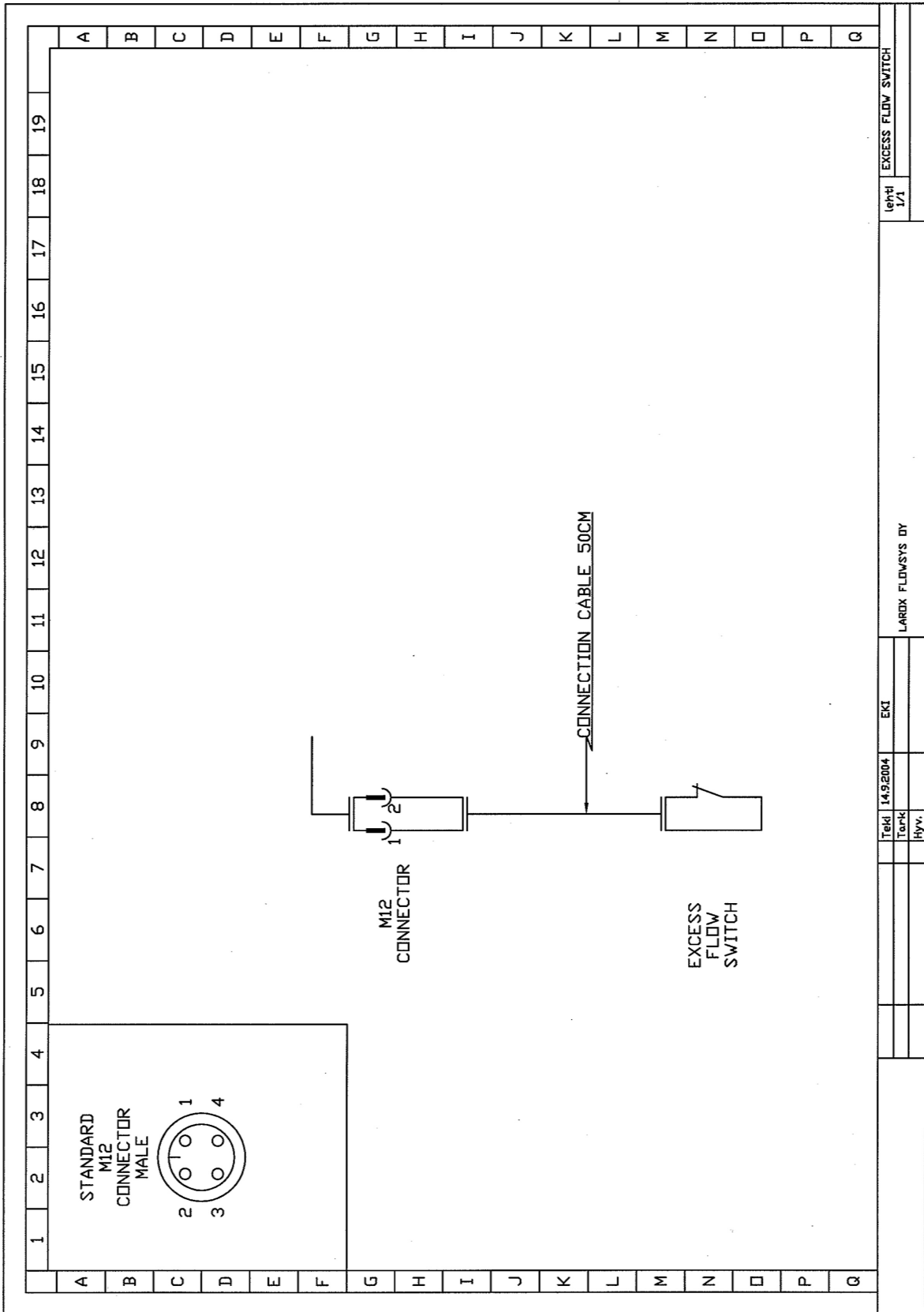

APPENDIX D: Dimensions, LPP-D pumps

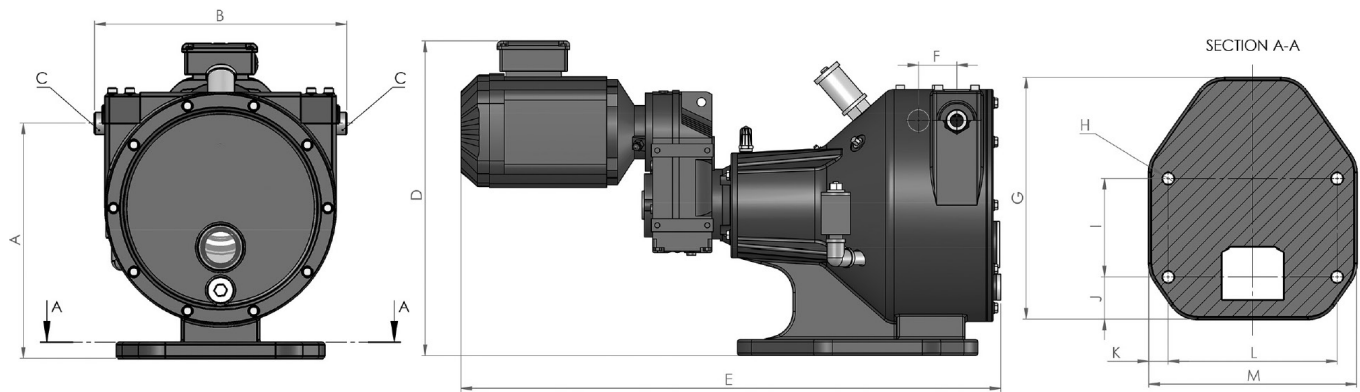

Pump model	A	B	C	D	E	F	G	H	I	J	K	L	M
LPP-D25 (GM: SEW FAF37, 1.5kW)	360 / 14.17"	388 /15.28"	G1"	482 /18.98"	831 / 32.7"	59 / 2.32"	370 (14.57")	4 X 19 (0.75")	150 (5.91")	65 (2.56")	30 (1.18")	260 (10.24")	320 (12.6")
LPP-D20 (GM: SEW FF27, 1.1kW)	285 / 11.22"	325 / 12.8"	G3/4"	414 / 16.31"	853 / 33.58"	50 / 1.97"	320 / 12.58"	4 X 19 (0.75")	85 / 3.35"	65 (2.56")	26 / 1"	240 / 9.45"	291 / 11.46"
LPP-D15 (GM: SEW FF27, 1.1kW)	285 / 11.22"	325 / 12.8"	G1/2"	414 / 16.31"	853 / 33.58"	50 / 1.97"	320 / 12.58"	4 X 19 (0.75")	85 / 3.35"	65 (2.56")	26 / 1"	240 / 9.45"	291 / 11.46"

Dimensions with the largest available motor size

APPENDIX E: General safety warnings

Lifting

1. Always use a lifting plan created by a qualified person to lift this equipment. Lifting guidance is provided in this IMO (Installation, Maintenance and Operation manual) to assist in lifting plan development. Think about the center of gravity (CG) of the equipment being lifted. Make sure the CG is always under the central lifting point.
2. Use only correct and approved lifting devices. Ensure that lifting devices and straps are securely attached to the equipment prior to lifting.
3. Check, that lifting devices are not damaged and in good condition with a valid check stamp prior to use.
4. Workers must be trained for lifting and handling pumps.
5. Never lift an assembly by the instrumentation (drive unit). Failure to follow the lifting guidance provided may result in damage and personal injury from falling objects.

Work activities on the pump

1. Wear your personal safety equipment. Personal safety equipment includes but is not limited to protective shoes, protective clothing, safety glasses, helmet, hearing protection and working gloves.
2. Always follow the local safety instructions in addition to the Valmet instructions. If Valmet instructions conflict with local safety instructions, stop work and contact Valmet for more information.
3. Before beginning service on the equipment, make sure that the drive unit is disconnected from any kind of power source (hydraulic, and/or electric), and no stored energy is applied on the drive unit.
4. Make sure that there is a LOTOTO (Lock Out / Tag Out / Try Out) procedure in place for the system in which the pump is installed and strictly follow it.
5. Always make sure that the pipeline is depressurized and in ambient temperature condition before maintenance work is started.
6. Keep hands and other body parts out of the flow port when the pump is being serviced and the drive unit is connected to the pump. There is a high risk of serious injury to hands and/or fingers due to malfunction if the pump suddenly starts to operate.

General disclaimers

Recieve, handle and unpacking

1. Respect the safety warnings above!
2. Pumps are critical components for pipelines to control high pressure fluids and must therefore be handled with care.
3. Store pumps and equipment in a dry and protected area until the equipment is installed.
4. Do not exceed the maximum storage temperatures given in the IMO (installation, maintenance, and operating instructions).
5. Keep the original packaging on the pumps as long as possible to avoid environmental contamination by dust, water, dirt, etc.
6. FOR YOUR SAFETY IT IS IMPORTANT THE FOLLOWING PRECAUTIONS BE TAKEN PRIOR TO REMOVAL OF THE PUMP FROM THE PIPELINE OR BEFORE ANY DISASSEMBLY:
 - Be sure you know what fluid is in the pipeline. If there is any doubt, confirm with the proper supervisor.
 - Wear any personal protective equipment (PPE) required for working with the fluid involved in addition to any other PPE normally required.
 - Depressurize the pipeline, bring to ambient temperature, and drain the pipeline fluid.
 - Cycle the pump to relieve any residual pressure in the body cavity.
 - After removal but before disassembly, cycle the pump again until no evidence of trapped pressure remains.

Operating

1. The type plate (nameplate, or engraved markings) on the pump gives the information of max. process conditions to the pump.
2. Temperatures and pressures must never exceed values marked on the pump. Exceeding these values may cause uncontrolled release of pressure and process fluid. Damage or personal injury may result.
3. Valmet pumps typically are designed to be used in atmospheric conditions. Do not use pumps under external pressurized conditions unless specifically designed and explicitly marked for this service.
4. Avoid Pressure shocks or water hammer. Systems with high pressure pumps should be equipped with a bypass to reduce the differential pressure before opening the pump to avoid pressure shock.
5. Avoid thermal shock. High temperature, Low temperature pumps should be operated in a way that limits the rate of increase or decrease in temperature. The pump should be thermally stabilized before being pressurized.
6. Materials of the pump are carefully selected for the process conditions. Changes to the process media can have a major impact on function and safety of the pump. Always confirm the materials are suitable for the service prior to installation.
7. As the use of the pump is application specific, a number of factors should be taken into account when selecting a pump for a given application. Therefore, some situations in which the pumps are used are outside the scope of this manual.
8. It is the end user's responsibility to confirm compatibility of the pump materials with the intended service, however if you have questions concerning the use, application, or compatibility of the pump for the intended service, contact Valmet for more information.
9. Never use a pump with enriched or pure oxygen if the pump is not explicitly designed and cleaned for oxygen. Selected materials and design have a major impact on the safety to operate the pump with oxygen.
10. Pumps intended for use in or with explosive atmospheres must be equipped with a grounding device and marked according ATEX (or equivalent international standards).

Maintenance

1. Respect the safety warnings above!
2. Plan service and maintenance actions, that spare parts, lifting devices and service personnel is available.
3. Maintain the pump within the recommended minimum maintenance intervals or within the recommended maximum operating cycles.
4. Always make sure that the pump and the pipeline is depressurized before starting any kind of maintenance work at a pump.
5. Always check the position of the pump before starting maintenance work. Follow the Lock out /tag out (LOTO) rules at the site before starting any maintenance activity.
6. Sealing materials (soft sealing parts) should be changed when the pump is maintained. Always use original equipment manufacturers (OEM) spare parts to ensure proper performance of the repaired pump.
7. All pressure containing parts must be inspected visually for damage or corrosion. Damaged parts must be replaced.
8. Pump pressure bearing parts and all internals must be inspected for corrosion or erosion which may result in reduced wall thickness on pressure bearing parts. Damaged pressure bearing parts must be replaced with original equipment manufacturers (OEM) replacement parts or repaired to factory specifications by an authorized Valmet service partner in order to maintain the warrantee.
9. Do not use sharp tools, grinding machines, or files to work on functional surfaces such as sealing, seating or bearing surfaces as this can damage these surfaces.
10. Check the condition of sealing surfaces on the seats. Replace parts if there are significant wear, scratches, or damage.
11. Check the wear of bearings and bearing contact surfaces on the shaft and replace damaged parts if necessary.
12. Do not weld on pressure bearing parts without an ASME and PED qualified procedure and personnel.
13. Pressure bearing parts of pumps in high temperature applications must be carefully examined for the effects of material creep and fatigue.
14. Make sure that the pump is positioned in the correct flow direction into the pipeline.
15. If the pumps are marked to be suitable for explosive atmospheres, the correct function of the discharging device must be tested before returning to service.
16. Always work in a clean environment. Avoid getting particles inside the pump due to machining, grinding, or welding nearby.

17. Never store a maintained pump without flow port protection.
18. When pressure testing pumps, never exceed the maximum operating pressure of the system on the pump identification plate.
19. Drive unit mounting and unmounting:
 - Before installing the drive unit on to the pump, be sure the drive unit is properly indicating the pump position. Failure to assemble these to indicate correct pump position may result in damage or personal injury.
 - When installing or removing an adapter set, best practice is to remove the entire drive assembly, including couplings which may fall off the pump during lifting or when position changes.
 - Adapter sets have been designed to support the weight of the Valmet drive unit and recommended accessories. Use of the adapter sets to support additional equipment or additional weight such as people, ladders, etc. may result in equipment damage or personal injury.
20. The pump should be installed between flanges using appropriate gaskets and fasteners that are compatible with the application, and in compliance with applicable piping codes and standards. Center the gaskets carefully when fitting the pump between the flanges. Do not attempt to correct pipeline misalignment by means of the flange bolting.
21. Repairs on pump for special service like Oxygen, Chlorine, and Peroxide, have special requirements.
 - Parts must be cleaned appropriate to the service and protected from contamination prior to assembly.
 - Assembly areas and tools must be clean and dry to prevent contamination of the parts during assembly.
 - Test equipment must be clean and dry to prevent contamination during testing. This includes the test equipment internals that may allow particles or other contamination into the test fluid during the test.
 - Lubrication shall be used only if specifically required in the instructions. Where lubrication is required, the lubricant must be approved for the service by the end user.

Valmet Flow Control Oy

Marssitie 1, 53600 Lappeenranta, Finland.

Tel. +358 10 417 5000

www.valmet.com/flowcontrol

Subject to change without prior notice. Neles, Neles Easyflow, Jamesbury, Stonel, Valvcon and Flowrox, and certain other trademarks, are either registered trademarks or trademarks of Valmet Oyj or its subsidiaries in the United States and/or in other countries. For more information www.neles.com/trademarks

