

Jamesbury ball valves

5RRR, 5RFF, 5RRT and 5RFT

Tank-Car Fire-Tite™

top-loading and unloading valves

1" (DN 25)

Installation, maintenance and
operating instructions

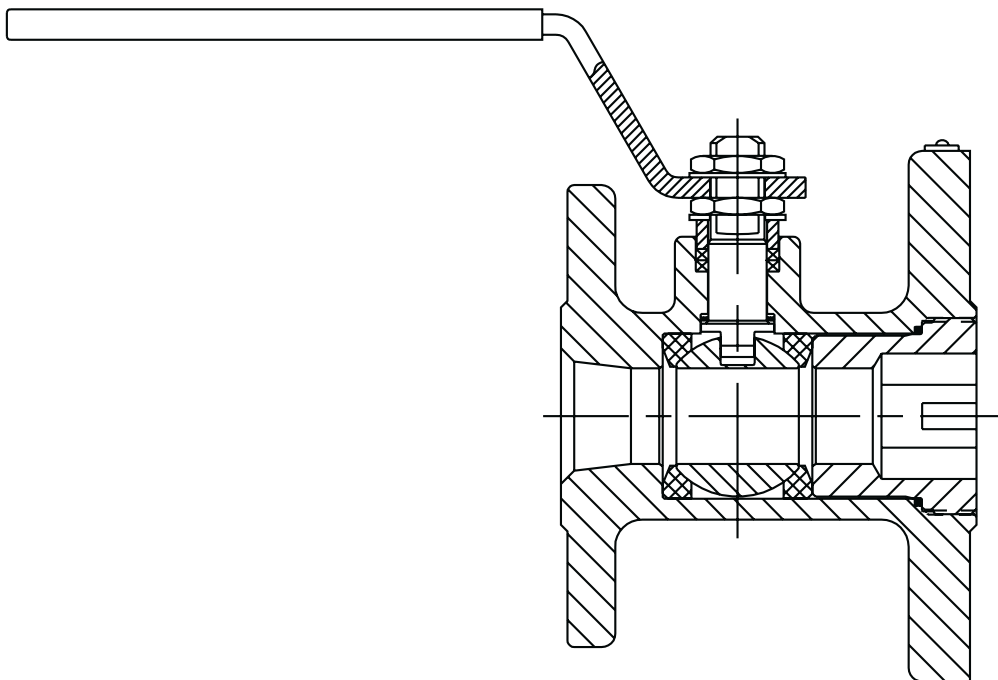

Table of contents

GENERAL	3
Warning	3
INSTALLATION	3
MAINTENANCE	3
Disassembly	3
Assembly	4
REPAIR KITS/ SPARE PARTS	4
SPECIFIC BODY STYLES	5
EXPLODED VIEW & PARTS LIST	6

READ THESE INSTRUCTIONS FIRST!

These instructions provide information about safe handling and operation of the valve.

If you require additional assistance, please contact the manufacturer or manufacturer's representative.

SAVE THESE INSTRUCTIONS!

Addresses and phone numbers are printed on the back cover.

1. GENERAL

This instruction manual contains important information regarding the installation, operation and troubleshooting of the Jamesbury™ 1" (DN 25) 5RRR, 5RFF, 5RRT and 5RFT Tank-Car *Fire-Tite* Top-Loading and Unloading Valves. Please read these instructions carefully and save them for future reference.

1.1 WARNING

FOR YOUR SAFETY, IT IS IMPORTANT THAT THE FOLLOWING PRECAUTIONS BE TAKEN PRIOR TO REMOVAL OF THE VALVE FROM THE LINE OR BEFORE ANY DISASSEMBLY.

1. WEAR ANY PROTECTIVE CLOTHING OR EQUIPMENT NORMALLY REQUIRED WHEN WORKING WITH THE FLUID INVOLVED.
2. DEPRESSURIZE THE LINE AND CYCLE THE VALVE AS FOLLOWS:
 - A. PLACE THE VALVE IN THE OPEN POSITION AND DRAIN THE LINE.
 - B. CYCLE THE VALVE TO RELIEVE RESIDUAL PRESSURE IN THE BODY CAVITY BEFORE REMOVAL FROM THE LINE.
 - C. AFTER REMOVAL AND BEFORE ANY DISASSEMBLY, CYCLE THE VALVE AGAIN SEVERAL TIMES.
3. SEAT AND BODY RATINGS - THE PRACTICAL AND SAFE USE OF THIS PRODUCT IS DETERMINED BY BOTH THE SEAT AND BODY RATINGS. READ THE NAME TAG AND CHECK BOTH RATINGS. THIS PRODUCT IS AVAILABLE WITH A VARIETY OF SEAT MATERIALS. SOME OF THE SEAT MATERIALS HAVE PRESSURE RATINGS THAT ARE LESS THAN THE BODY RATINGS. ALL OF THE BODY AND SEAT RATINGS ARE DEPENDENT ON VALVE TYPE AND SIZE, SEAT MATERIAL, AND TEMPERATURE. DO NOT EXCEED THESE RATINGS.

2. INSTALLATION

Flow through these *Jamesbury* valves can be in either direction. In the case of a tongue and groove connection, however, the tongue is installed against the tank car.

Follow the recommended practices of the gasket manufacturer when tightening flange bolts.

If there is weepage past the stem seals upon installation, it means the valve may have been subject to wide temperature variations in shipment. Leaktight performance will be restored by a simple packing adjustment described in the **MAINTENANCE** Section.

3. MAINTENANCE

Routine maintenance consists of tightening the lower stem nut (16) to 100 - 110 IN•LBS (11 - 12 N•m) periodically to compensate for the wear caused by the stem turning against the stem seals. More frequent observation is recommended under extreme operating conditions. The upper stem nut (16) should be retightened. Overhaul maintenance consists of replacing seats and seals. A standard repair kit consisting of these parts may be obtained from your Valmet distributor (see **Table 1**).

Valve	Kit No.
PTFE Seats	RKR-50TT
Filled PTFE Seats	RKR-50MT

3.1 DISASSEMBLY

1. Read the instructions in the **WARNING** section.
2. Place the valve in the open position.
3. Remove the stem nut (16), shakeproof washer (19), handle (17), stem nut (16), stem washer (50), and compression ring (21).
4. Place the valve in a vertical position with the insert end up.
5. Unscrew and remove the insert (2) and body seal (6).
6. Place the ball into the closed position and remove the top seat (5) and the ball (3). If these parts do not lift out easily, take a piece of wood or some other soft material object and gently tap the ball from the end opposite the insert. This will unseat these parts without damaging them.
7. Press the stem (4) into the valve body cavity. It may be necessary to tap it with a piece of wood or some other soft material.
8. Remove the stem, then pry out and discard the old stem seals (8), the stem bearings (24) and secondary stem seal (7).
9. Carefully remove the bottom seat (5) out of the body, taking caution that the body seat face is not scratched while doing so.

3.2 ASSEMBLY

Apply a lubricant compatible with the flow medium lightly to seats, seals, ball, and stem to facilitate assembly and for ease of initial operation.

1. Slide one valve seat (5) sidewise into the body cavity (1) to just below the stem hole and tilt it into place so that the proper face will come in contact with the ball (3) (see **Figure 1**). Do not scratch or cut the seat faces.

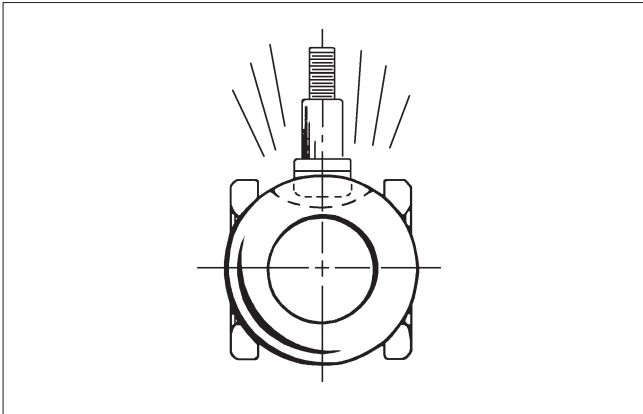
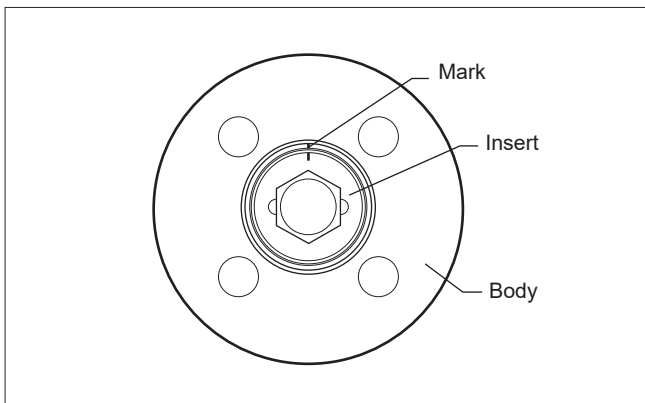

Figure 1.

2. From inside of the body cavity, insert one stem bearing (24), the secondary stem seal (7), then the second stem bearing (24) up into the lower stem counterbore.
3. From the outside of the body, insert the two stem seals (8) into the upper stem counterbore.
4. Insert the stem (4) into the body cavity (threaded end first), and press it gently up into the stem bore until resistance is felt from the lower stem bearing. Be careful not to scratch seals.
5. Holding the stem in place from inside the body, drop the compression ring (21) and stem washer (50) over the threaded end of the stem protruding out of body stem bore, then screw on the stem nut (16).
6. Tighten down the stem nut until the stem comes snugly into place, then torque stem nut to 70 – 80 IN•LBS (8 – 9 N•m). Rotate the stem gently to assure proper seating.
7. Screw the insert (2) into the body until it is fully seated. Mark the position as shown in (**Figure 2**). Counting the number of turns, remove the insert.



8. Insert the ball (3) rotating it onto the stem (4) in the closed position. If necessary, turn the stem blade to align with the ball slot.
9. Insert the second seat (5) so that the sealing surface of the seat is towards the ball (see **Figure 1**).

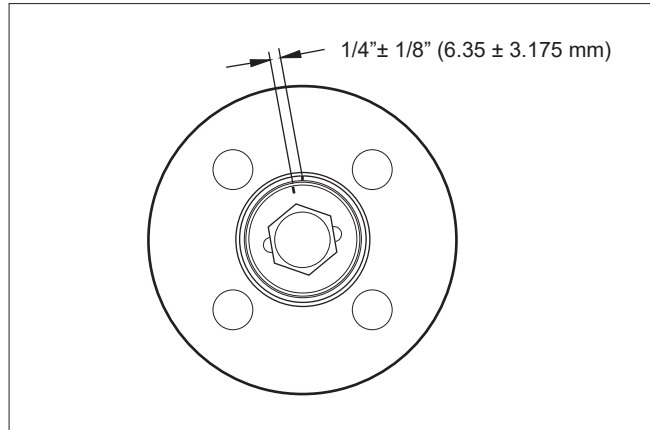

Figure 2.

10. Insert the body seal (6) and gently press it into the groove in the body.
11. Using a thread lubricant compatible with the media, screw the insert (2) into the body and tighten to 125 – 150 FT•LBS (170 – 203 N•m). If a torque wrench is not available, tighten the insert the same number of turns as in Step 7 until the marks match the illustration (shown in **Figure 3**).
12. Place the handle (17), shakeproof washer (19), and stem nut (16) on the valve stem and torque stem nut to 70 – 80 IN•LBS (8 – 9 N•m). Cycle the valve slowly with a gentle back and forth motion to build gradually to the full quarter turn. A fast turning motion at this point may cut the seats before they have a chance to form the proper seal.

4. REPAIR KITS/SPARE PARTS

For further information on spare parts and service or assistance visit our web-site at <https://www.neles.com/products/valves/railroad-valves/catalogue-of-tank-car-valves/>.

5. SPECIFIC BODY STYLES

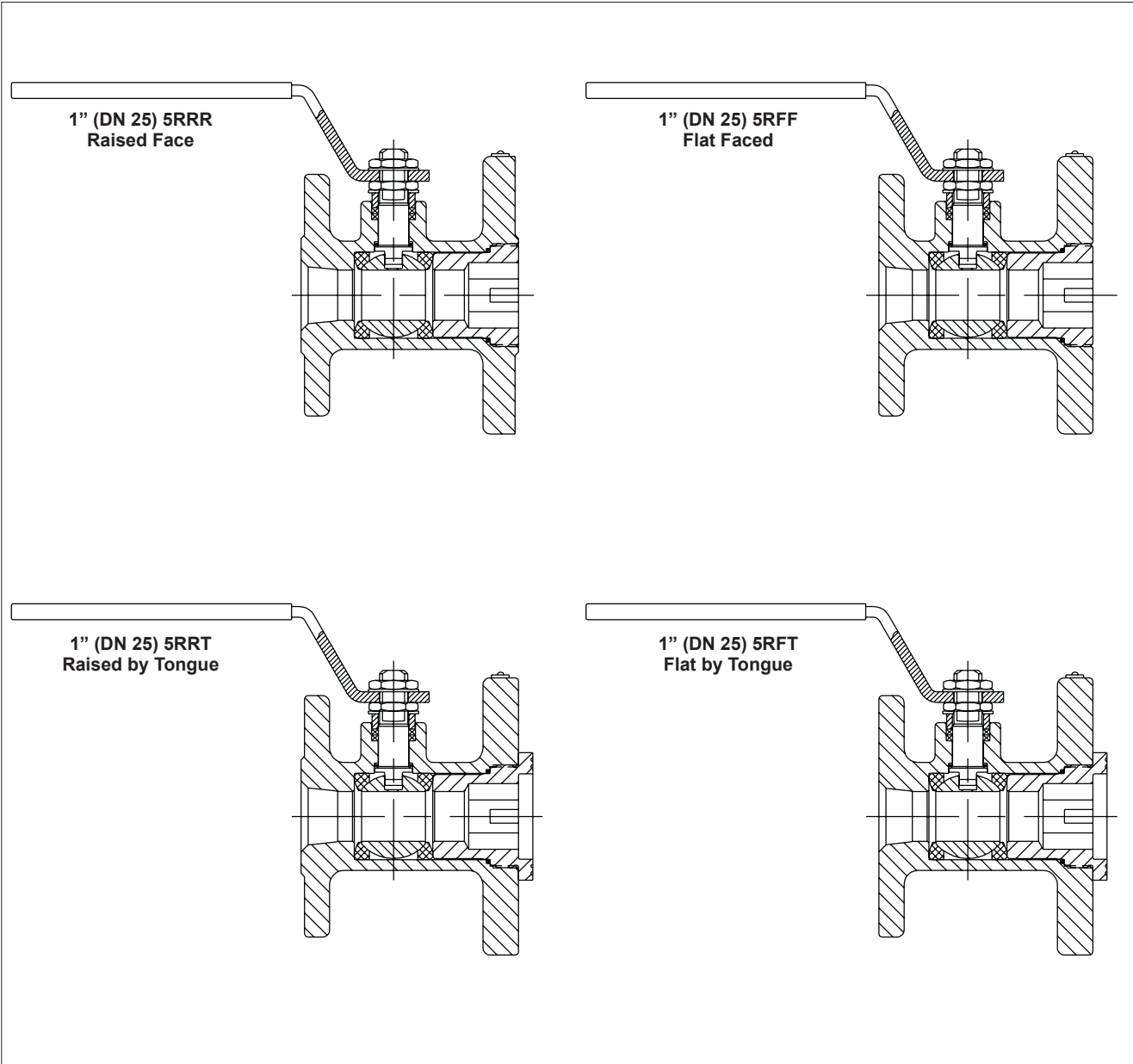

Figure 3.

6. EXPLODED VIEW & PARTS LIST

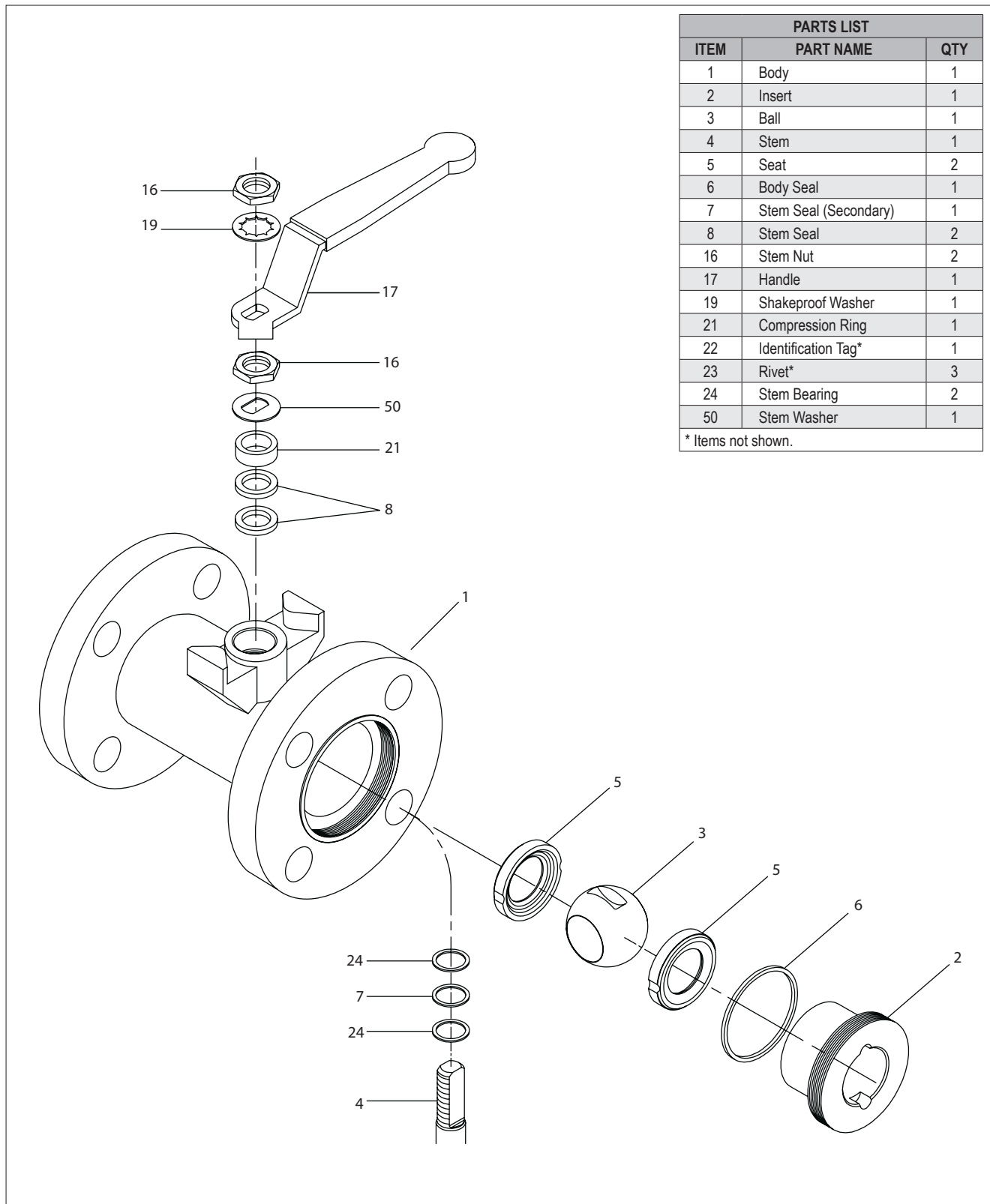

Figure 4.

Valmet Flow Control Oy

Vanha Porvoontie 229, 01380 Vantaa, Finland.

flowcontrol@valmet.com

Tel. +358 10 417 5000.

www.valmet.com/flowcontrol

Subject to change without prior notice.

Neles, Neles Easyflow, Jamesbury, Stonel, Valvcon and Flowrox, and certain other trademarks, are either registered trademarks or trademarks of Valmet Oyj or its subsidiaries in the United States and/or in other countries.

For more information www.neles.com/trademarks

